

An Adventure for use with  
**STAR TREK**®  
THE ROLE PLAYING GAME

# DEMAND OF HONOR



fasa

# TABLE OF CONTENTS

<b>Introduction</b> .....	3
<i>Plot Synopsis</i> .....	3
<i>Description</i> .....	3
<b>The Adventure</b> .....	4
<i>Setting The Stage</i> .....	4
<i>Journey To Maltharin II</i> .....	5
<i>Events At Maltharin II</i> .....	9
<b>Maps</b> .....	14
<i>The Outpost Maps</i> .....	14
<i>The Administration Building</i> .....	14
<i>Shield Generator Building</i> .....	14
<b>Pull-Out Section</b>	
<i>Master Control Panel</i>	
<i>Damage Control Display</i>	
<i>Weapons Panel</i>	
<i>Administration Building</i>	
<i>Engineering Panel</i>	
<i>Shield Generator Building</i>	
<i>Deflector Shields Panel</i>	
<i>Gorn Courier (Deck 2)</i>	
<i>Helm Panel</i>	
<i>Gorn Courier (Deck 1)</i>	
<i>Sensors Panel</i>	
<i>Damage Control Panel</i>	
<i>Overall Map</i>	
<i>Weapons Systems Panel</i>	
<b>Vessels</b> .....	35
<i>Larson Class Destroyer</i> .....	35
<i>Gorn Alliance Ships</i> .....	35
<b>Background Information</b> .....	36
<i>Arena: The First Contact</i> .....	36
<i>The Clanhaven Conference</i> .....	36
<i>The Gorn Alliance</i> .....	36
<i>Maltharin II</i> .....	37
<b>Cast Of Characters</b> .....	38
<i>Crew Of The USS Hastings</i> .....	38
<i>Secondary Officers</i> .....	43
<i>Incidental Officers And Crewmen</i> .....	43
<i>The Passengers</i> .....	44
<b>Hints For Play</b> .....	49
<i>Judging The Adventure</i> .....	47
<i>Outcomes Of The Adventure</i> .....	48
<i>Altering The Adventure To A Campaign In Progress</i> .....	48



***DEMAND OF HONOR***

*Written by* J. Andrew Keith, Marischal Adventures

*Edited by* Wm. John Wheeler

*Maps and Layout by* Dana Knutson

*Art by* Lisa Kolek

*Typeset by* Karen Vander Mey

*Playtested by* Tom Kokkelenberg, Dave Hoffman, Larry Gniadek, Michael Messenger,  
Mike Lichter, Dave Fulton, Debbie Fulton, and William H. Keith, Jr.

Published by FASA Corporation, P.O. Box 6930, Chicago, IL 60680

Copyright 1966, 1984. Paramount Pictures Corporation  
STAR TREK is a trademark of Paramount Pictures Corporation  
STAR TREK: The Role-Playing Game is manufactured by FASA  
Corporation under exclusive license from Paramount Pictures Corporation, the trademark owner.

# INTRODUCTION

## PLOT SYNOPSIS

**Demand Of Honor** is designed for characters aboard the 95,000-ton, *Larson-class* destroyer, *U.S.S. Hastings*. The adventure follows the crew of the *Hastings* in a mission to stop a band of Gorn who belong to a discredited faction of the Alliance government. Their attacks on Federation shipping along the frontier, entirely without the sanction of the Alliance government, are attempts to sabotage the peace talks between the UFP and the Gorn Alliance. The Gorn concepts of honor and obligation, which are difficult for outsiders to understand, could be a major stumbling block to settling the problem without causing serious difficulties at the conference table.

The *Hastings* is summoned from a routine patrol to the site of the peace talks, as described in **The Message**. The vessel is ordered by the sector Admiral to take a diplomatic party aboard, as discussed in **The Admiral's Briefing**. The head of this party is S'slee, a Gorn of considerable importance; he is obligated to deliver a formal message requesting the submission of the Gorn renegades. Failure to deliver this message would be a serious breach of tradition. Only after this message has been delivered can the Federation take active steps to counter the threat posed by the renegades.

The mission is a touchy one, for Gorn concepts of conduct are difficult for Humans to grasp, and the Alliance representatives could be offended easily. Worse, there is a potentially dangerous situation aboard the *Hastings*, for her Security Chief, Lt. Travers, is the son of the Base Commander killed in the massacre at Cestus III during the first Gorn incursion into Federation space. This is detailed in **An Old Grudge**. That S'slee commanded the raid is revealed in **Distinguished Passengers**.

Enroute to Maltharin II, where the Gorn renegades are believed to be based, tension between Lt. Travers and S'slee is established as described in **Travers Meets S'slee**. Later, the Security Chief's phaser is found, set on overload, in S'slee's cabin. Although Travers has an alibi, Slas'sarn, one of S'slee's aides, expresses distrust of Federation motives and intentions. This is described in **The Assassination Attempt**.

Hard on the heels of this incident, a distress call from the overdue Gorn courier is intercepted, as described in **Distress Call**. Under attack, the courier is only a short distance away, and the *Hastings* may (or may not, at the Captain's option) alter course to render assistance. Failure to do so would result in strained relations with the Gorn diplomats, as described in **A Question Of Honor**.

If the ship does alter course to answer the distress call, it discovers a derelict courier as described in **The Derelict**. While a boarding party investigates, as described in **The Boarding Party**, a Gorn cruiser launches an attack from ambush. This vessel can be fended off, possibly with the aid of the damaged courier, which may be repaired enough to participate. The cruiser is no real match for the *Hastings*, and it will flee after taking some damage. These events are discussed in **The Starship Combat**.

Following the battle, Slas'sarn attempts to leave in the courier to report on the situation to the embassy. Secretly in league with the renegades, he really wants to leave *Hastings* before she sails into a trap, as discussed in **Aftermath**.

When the *Hastings* reaches Maltharin II, using sensors from a standard orbit reveals no sign of life around the Gorn base there, as outlined in **The Hastings In Orbit**. The Gorn

and a handful of ship's officers and crew must be beamed down to deliver S'slee's message. The events that culminate in the appearance of the landing party in the middle of the outpost are described in **The Landing Party** and **Beaming Down**. The Gorn renegades are waiting in ambush, and the landing party is taken prisoner, as described in **The Ambush**.

The renegades, led by Slas'sarn, have a plan to drive a wedge between the Federation and the Alliance government. The *Hastings* is permitted to intercept a message, purportedly at the instigation of S'slee, though he is, in fact, a prisoner along with the rest of the landing party. As described in **The Hastings Reacts**, the message orders two Gorn vessels to close in and destroy the *Hastings*. The renegade plan can succeed in several ways: the *Hastings* may be destroyed, in which case the Federation will be sure that the Gorn are treacherous, or it may abandon the landing party and withdraw, convincing S'slee that the Federation has proven unfaithful.

If the *Hastings* remains behind, it may risk battle and attempt to rescue the captives, using a phaser overload to batter down the normally impregnable base shields. This is discussed in **Overload** and in **Turkey Shoot**. Once the shields are down, a rescue party may be beamed into the outpost or near it, taking a chance that they will not be caught by the shields as they are restored to action. These possible plans are described in **Beaming Through The Gap**, **Running The Gauntlet**, and **Behind Enemy Lines**. At the same time, the imprisoned landing party may escape, as described in **Escape**. The nature of Slas'sarn's treacherous plan will come to light when S'slee has been rescued, as told in **Rescuing S'slee**.

The climax of the adventure comes when two Gorn cruisers square off against the *Hastings*, as told in **Battle In Space**. The two Gorn cruisers are roughly equal to the *Hastings*, and thus who wins the combat is dependent upon the skill of the players and the abilities of their player characters. The adventure's outcome depends on the exact events that have occurred. Many possibilities are available, from the start of a Federation-Gorn war to the end of the renegade menace.

## DESCRIPTION OF CONTENTS

This booklet contains all of the information needed to play this adventure. Descriptions of all encounters are provided as described above. Also included are brief descriptions of the areas shown on the maps, complete background information for players, and gamemaster hints for play.

Information on the *Hastings* crew also is provided, including complete information on the senior officers. Sufficient detail is included to allow these characters to be used as player characters, which permits a game to be started up at once. Also included are details on the diplomats and on secondary and incidental officers aboard the *Hastings*. If these characters are not used, the character sheets may be added to the gamemaster's file for later use.

The center of this booklet is a pull-out section. This includes the physical materials needed to play the game: maps and deck plans, consoles, panels, and data sheets. For the *Hastings*, there is a ship data sheet and a console for each bridge officer. Deck plans of the Gorn courier are provided at tactical scale, and a ship data sheet is given for it. A ship data sheet and master control panels are provided for the Gorn cruisers. Permission is granted to photocopy these for reasonable personal use.

# THE ADVENTURE

## SETTING THE STAGE

### THE MESSAGE

The *Hastings* has been patrolling on the Gorn frontier for several months. Under terms agreed upon at the Clanhaven Conference, ships operating within 25 parsecs to either side of the frontier are limited in size to 100,000 tons or fewer to prevent the possibility of major misunderstandings and confrontations. Thus *Hastings* has taken on many of the duties of patrol, errand-running, and special missions that might normally fall to a much larger Federation vessel.

The ordinary course of patrols is interrupted by the receipt of the following urgent message from the Federation Enclave at Clanhaven, 3 days' journey away at maximum warp:

From: Embassy Enclave

Admiral J. Mendez, Star Fleet Liaison

To: Captain, U.S.S. *Hastings*

Patrol orders cancelled. Proceed at maximum repeat maximum warp to Clanhaven for new orders.

### THE ADMIRAL'S BRIEFING

Upon arrival at Clanhaven, *Hastings'* captain is ordered to beam down with his senior officers for a briefing. Specific officers in attendance would include the Executive Officer, Science Officer, Medical Officer, Chief Engineer, and Chief of Security; other officers can be included at the Captain's discretion.

Admiral Mendez, recently promoted to his position from a Star Base command, conducts the briefing in person, along with several junior diplomats. He gives the information below:

"A threat has arisen that could adversely affect the peace conference, and *Hastings* has been assigned to deal with it. Failure to meet the threat, and meet it quickly, could result in a complete breakdown in the talks, and the possible outbreak of war."

Mendez turns the briefing over to one of the junior officers, a diplomatic liaison lieutenant. She explains the following:

"While much of Gorn society and culture remains unknown, certain facts have gradually grown clear. The most important of these deal with the way the Gorn view government.

"The Alliance has long been ruled by two leaders with equal powers sharing power and responsibility for government. These two are answerable to a council, the main voice of a scattering of semi-independent Gorn worlds that make up the Alliance. The council has been divided into two major factions with regard to the Federation, and the two leaders have been split in their views as well.

"One of the two Autarchs and one faction of the council favors a negotiated settlement with the Federation; the other

Autarch and council faction favors war. Their basic goals are the same — freedom for the Gorn alliance to expand unchecked by outside powers is paramount to all. Only the methods of the two factions differ.

"This faction in favor of negotiated settlement disagreed with the raid on Cestus III which began the frontier crisis. Since the raid, they have been striving for a diplomatic approach to the whole problem. In addition, they are stubborn and intractable.

"The other Autarch, leading the faction in favor of war, ordered the Cestus III raid and placed his own son in command of it. A narrow majority of the council supported the move. The outcome of the raid proved the downfall of the actionist faction. The commander, the autarch's son, returned convinced that the Federation might be dealt with through diplomacy. The actionist party splintered. The Autarch gathered some stalwart supporters and departed, swearing never to abandon his people to the dishonor of serving a foreign, alien power.

"This rupture in Gorn government is one of the reasons that negotiations have dragged on so long."

As the liaison officer threatens to get too deeply engrossed in her lecture on Gorn society and goals, Admiral Mendez cuts her off and steers the briefing back to essentials, with the following information:

"Recently, the renegade Autarch turned up, apparently in command of a band of Gorn determined to wage war despite the council's decisions. This group has at least one (possibly more) Gorn cruisers, and has begun launching piratical attacks on Federation shipping in the frontier region. Three freighters have been reported lost in two weeks, and a Federation outpost has been destroyed.

"When reports of these attacks by a Gorn warship came in, the Alliance Ambassador did everything in his power to reassure the Federation representatives that this was not being carried out at the order of the Alliance government. It was established rapidly that this action was being carried out by renegades; indeed, the Alliance was even able to identify the location of the most likely base of operations for the Gorn pirates, an abandoned Gorn outpost world lying within the Federation-claimed sphere of influence, not far from the populous Federation colony world Veldenia V.

"The Gorn representatives have requested permission to deal with the situation themselves, under the precepts of their complicated system of honor and obligations. This request would have involved allowing a squadron of Gorn warships to assemble and enter Federation space. Star Fleet has not agreed, against the advice of certain members of the Diplomatic Corps. (This is said with a hard stare from the Admiral directed at the diplomats present.)

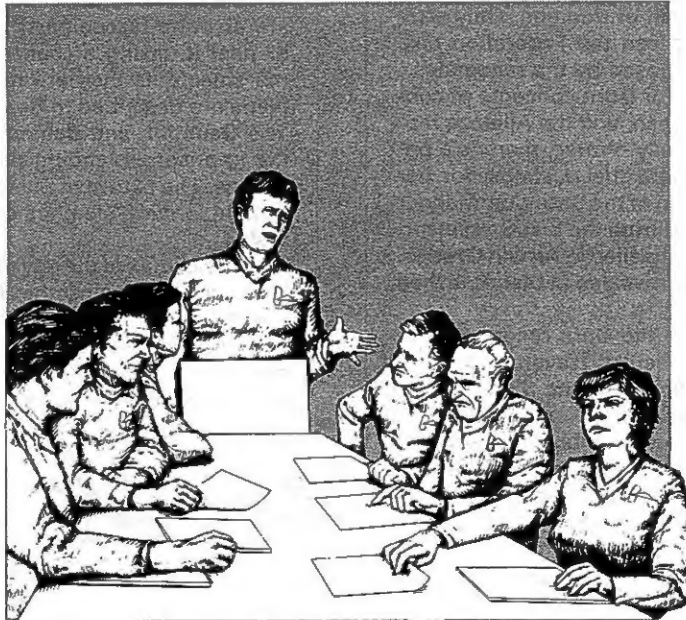

"Star Fleet feels that the situation is an internal security matter, and wishes to deal with it as such. But the proper course of action — a call for a *Constitution*-class starship to tackle the renegade outpost — cannot be implemented without permission from the Gorn, since the Frontier Accord would necessarily need to be suspended for the action. The Gorn won't give that permission, unless a specific condition is met.

"The Alliance representatives are unwilling to allow an attack on the renegades without first offering a chance of submission, and under their code of honor and conduct it is important that members of the Gorn embassy present this chance directly. It would be dishonorable to permit the Autarch and his followers to be faced with submitting to aliens from the Federation. The Gorn will allow Federation action only on the condition that they be permitted to deliver a personal message urging submission. Star Fleet has accepted this, deferring a summons of the nearest starship (the *Enterprise*) until the attempt has been made.

"Now, though, another problem has arisen. The Gorn ship orbiting Clanhaven and serving the diplomatic mission has suffered a breakdown of its entire navigational computer system, possibly an act of sabotage by secret actionist supporters among the Gorn delegation. A second courier expected from the Alliance is now a week overdue. Star Fleet cannot afford to wait much longer, for word of new attacks on Federation shipping has arrived. If something is not done soon, it will be necessary to call in the *Enterprise*, treaty or no treaty. To do so could solidify enough distrust and suspicion to cause the Alliance to repudiate all the negotiations and renew the war.

"The Gorn embassy has accepted an alternative. Embassy representatives are to be transported on their mission of peace aboard a Federation vessel, the *Hastings*. The ship will carry one of the Gorn ambassadors and a small retinue, along with a Federation diplomatic representative who will serve as liaison. Destination will be the planet believed to hold the Gorn outpost. Once the Gorn leader has delivered his message, the Captain is to act at his discretion, though the advice of the Gorn party and their Federation liaison should be consulted when possible."

At this point in the proceedings, the gamemaster should make sure that the players are aware that the Security Chief, Lt. Travers, is barely under control, looking ready to explode or break down. He does not actually say anything at this point, and Mendez tactfully ignores him, but ground-work should be laid at this point establishing his horror at the orders given by Mendez.

Mendez will give the *Hastings* party a chance to raise any questions and through him, the gamemaster will give the party a clue that background information exists that will be valuable to the players. Mendez also will impart a final warning:

"The destroyer's library computer will be updated with all relevant information on the Gorn that has been uncovered during the negotiations. In addition, Lt. Price, the diplomatic liaison officer who will accompany the *Hastings*, will have additional knowledge that can help fill in the blanks or answer questions that may arise.

"All must tread warily, for the Gorn are a proud race with a high regard for the honor, obligations, and responsibilities of the individual. A false step could destroy the hard-won gains of months at the conference table, and it could lead to a war as brutal as the Romulan War or the great confrontation with the Klingons only barely diverted by the Organian treaty. This, above all else, must not happen."

#### AN OLD GRUDGE

Shortly before the *Hastings* completes taking on stores for the voyage, and before the passengers are beamed

aboard, an obviously distressed Lt. Travers will request a meeting with the Captain. At this meeting, Travers is not quite hysterical or disrespectful enough to be insubordinate, but his hatred and fear of the Gorn is plain. The Security Chief voices his opposition to the "filthy, murdering, scaly, green monsters" who are to board the ship, claiming that the events are a trick to lure *Hastings* into an ambush.

Most responses from the Captain will elicit a more forceful denunciation of the Gorn as "treacherous murderers." Attempts made to have Travers say why he feels this way will bring him even closer to a breakdown, as he reveals that the Gorn killed his father — Base Commandant Travers of the *Cestus III* outpost.

How the Captain deals with Travers at this point will have a profound influence on future events. The least acceptable option is to leave Travers behind, not trusting him; especially if Travers is an NPC, players will naturally be suspicious of the gamemaster's motives in having him on board. A far more acceptable option would be to tell Travers that orders must be obeyed, and orders say to carry the Gorn.

Attempts to leave Travers behind will upset him almost as such as the Gorn do, for he is a dedicated officer who would see it as a black mark on his record. If the Captain insists on this course of action, he should be counselled that it is his least desirable option, as he would be risking Travers' good record (and the good name of his ship as well) without giving the officer a chance to prove himself.

Bringing Travers along is a far better idea. Given the apparent sabotage of the Gorn embassy ship, a paranoid Chief of Security is probably far more worthwhile for this mission than a more carefree one. Privately, the Captain may arrange to have Travers kept away from direct contact with the Gorn, and might warn the Medical Officer to keep an eye on the Security Chief.

#### DISTINGUISHED PASSENGERS

Shortly after the meeting between Travers and the Captain, the distinguished passengers are beamed aboard. Full dress and an honor guard would be not only well within acceptable practices, but probably virtually required given the circumstances. The Gorn are given to displays of power and to according courtesies to persons of rank; such a ceremony fills both purposes. There are 8 Gorn, including the leader, two aides, and 5 bodyguards. Accompanying them is Lt. Caroline Price, the diplomatic liaison officer who assisted Mendez at the briefing. Stats for the passengers are provided in a separate section of the booklet.

The Gorn leader is cordial, expressing delight at his first opportunity to see the inside of a Federation ship. He remarks that he has had far fewer opportunities to get to know Star Fleet officers than he would like... save, of course, for having had the honor of meeting the human Kirk. The Gorn confirms that he is S'slee, son of the Autarch of the Colonies, and once captain of the cruiser *Gress'sril*, which launched the raid on *Cestus III*. He displays a scar on his side, made by the discharge of Captain Kirk's crude but effective musket during their duel on the Metron-created planet near the edge of the frontier.

#### JOURNEY TO MALTHARIN II

Once the reception of the Gorn mission is completed, *Hastings* is ready to leave orbit and proceed to her destination. The navigational data provided by Admiral Mendez indicates that the Alliance believes the Gorn renegades to be operating out of an abandoned Gorn outpost on Maltharin II, an unpleasant, class M planet very near the frontier, about 10 days from Clanhaven at warp 6. Though maximum speed is indicated in the Admiral's orders, the trip is long enough to allow the gamemaster to develop any undercurrents that seem appropriate.



## TRAVERS MEETS S'SLEE

In particular, it might be interesting to have S'slee and Travers meet accidentally a time or two, in front of other player character witnesses. It would be quite difficult for one who does not know the Gorn intimately to tell one or another apart, except by clothing, and this fact could be exploitable by the gamemaster. One way or another, S'slee will eventually learn who Travers is, but will be quite unaware of the other's antipathy. Indeed, the Gorn will seek out the Security Chief to tell him that his father was a brave man, and died a warrior's death. This is a high compliment in Gorn society, but is likely to provoke an outburst from Travers.

The interplay between Travers and S'slee may be difficult for the gamemaster to stage properly, especially if both are NPCs. It can be dispensed with if desired, but it could become a truly great moment, with S'slee going on and on about what a great death Travers' father had, unaware of his effect on Travers until Travers blows up! The exchange is useful in establishing additional groundwork for future events.

When presenting confrontations of this kind, the gamemaster should implement them as isolated instances that stand out during the journey. In effect, these are scenes out of a *STAR TREK* episode that move the plot along. Just as *STAR TREK* shows only those scenes of significance to the story, so, too, the gamemaster need not plod through inconsequential detail, but can touch only on specific high points.

## THE ASSASSINATION ATTEMPT

On the sixth day of the trip, the Captain, one or two officers, and Lt. Price (who is present just about any time that the Gorn interact with the Federation crew) will be invited to S'slee's cabin for a drink and some quiet conversation. They are shown in by Slas'sarn, one of the two aides, who is then dismissed. S'slee wishes to ask the captain about his experiences with other great alien empires, such as the Klingons and the Romulans.

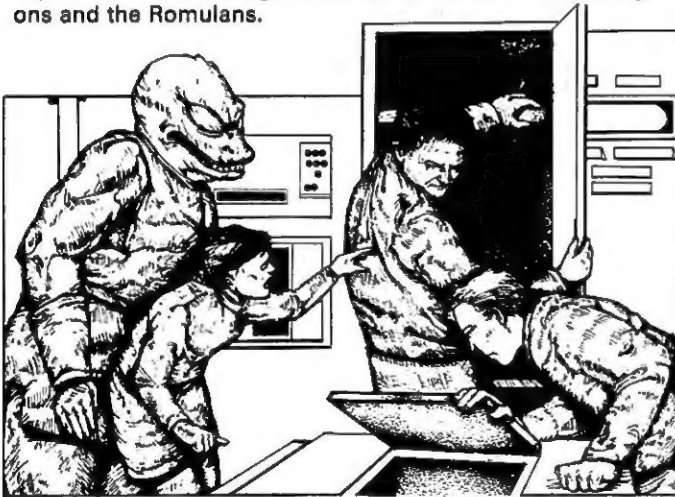

Before the conversation gets any further, the characteristic whine of a phaser on overload is heard. A search for the weapon allows each individual to roll once against LUC to find it behind a lighting panel. It may be disarmed or dropped into a corridor disposal chute when found, and will cause only minimal damage there. The object of this incident is not to kill the Captain, the Gorn, or anyone else. Scare them, yes, but they should be permitted to discover and disarm or dispose of the weapon in time.

This attempt could only be a deliberate assassination attempt. Travers is the obvious suspect, especially because the phaser was his prized possession, given him by his father when he passed his first Cadet Cruise (as will be discovered if the weapon is merely disarmed). Luckily for Travers, he was in Sick Bay taking his physical throughout the time when the phaser might have been placed in S'slee's cabin.

The attack was, in fact, instigated by Slas'sarn, an actionist traitor in the Gorn party, but this should not yet be revealed. The intention of the attempt was to make S'slee suspicious of Travers and of the officers who defend the Security Chief. It succeeds well, making things very tense indeed. Slas'sarn turns up again in time to join in the recriminations and begins preaching a highly anti-Federation line. S'slee expresses doubts about the honesty of Federation intentions.

The speculations that players are sure to begin making should be cut short. The gamemaster should time things so the party realizes that real trouble is brewing, but does not have time to begin to solve the questions being raised. When this crucial time is reached, the ship is ordered to Yellow Alert by the watch officer on the bridge, and the intercom giving the urgent summons "Captain to the bridge... Captain to the bridge."

## DISTRESS CALL

The source of the alert is a subspace radio call just intercepted by the Communications watch officer. The call is a regular, repeating signal in a non-Federation tongue. Cutting in the Universal Translator reveals that the call is a distress signal.

"Vessel in distress. Vessel in distress. Alliance courier shuttle *Sess'lessar* in distress. Vessel in distress..." The message repeats several times, apparently on automatic. Then the call is interrupted by a new signal, much less distinct, and subject to intermittent fading. It does not repeat.

"Courier shuttle *Sess'lessar* under attack. Shields are down; power near zero. Attacker is... closing for... attack run... Need assistance... Alliance or Federation vessel, respond... please... name of peace." The call then fades out, and neither it nor the original repetitive distress call is picked up again.

The language of the transmission is Gorn, as the library computer, Lt. Price, or any of the Gorn can tell the characters. The Gorn can also confirm that the first part was a computer-generated automatic distress beacon, activated when a ship is in danger. The second message was from a Gorn crewman. The *Sess'lessar* is the overdue courier vessel expected at Clanhaven.

The most reasonable course for the Captain is to order *Hastings* to assist the Gorn ship. Interstellar law calls for Federation vessels to render all possible assistance to ships in distress, except where so doing would jeopardize the rescuers. Rendering aid to the Gorn courier might also be a good way to restore S'slee's confidence in the honorable intentions of the Federation. The signal's origin point is less than half an hour away at Warp 6, and not very far off the destroyer's current heading.

Gorn delegation becomes visibly upset, maintaining that "Honor demands aid be rendered." Lt. Price will make an extra plea to the Captain to investigate before the Gorn are further offended. Should Lt. Travers be present during any part of these discussions, he will argue most vigorously against diverting course. He believes strongly that the distress call is a trap designed to lure *Hastings* into an ambush.

In the final analysis, though, this is the Captain's decision to make. The two sides of the argument — the Gorn and Lt. Price on the one hand, and Lt. Travers on the other — should be presented in a balanced fashion. Input from other senior officers (particularly the First Officer and the Science Officer) should be encouraged, as well. In the end, however, the Captain will make a choice.

If the Captain does decide to render aid, S'slee and Lt. Price both will be in full agreement. The next encounter will be **The Derelict**, as described below. If the Captain decides to continue on course and ignore the distress call, the next series of events will be **A Question Of Honor**, which follows; this will occur *only* if the Captain chooses to ignore the distress call.

## A QUESTION OF HONOR

These events will occur only if the Captain's final decision is to avoid the source of the distress call. The Gorn stalk away in disgust, and they remain in their cabins for the rest of the voyage, being completely unsympathetic to the player characters. They continue to fulfill their mission (for Honor demands it) but will not voluntarily assist the *Hastings* in any way. All attempts by the Federation characters to talk will be rebuffed, regardless of skills used or the form of approach attempted.

One way out of this situation does exist; the players may think of it, or Lt. Price will suggest it, *if her advice is asked*. The only way to get through to S'slee and the other Gorn is to approach them through the acceptable paths of their own culture — by reminding them of their duty and maintaining that the captain's decision was also made on the basis of a 'demand of Honor.'

The acceptable way of settling conflicting 'demands' in Gorn society is to engage in single combat. There is a chance that this won't be necessary — that the very fact of approaching the Gorn on their own ground will be sufficient. To resolve this, the Captain will need to make a successful Skill Roll against his rating in *Negotiation/Diplomacy*. Should the roll fail, the Gorn will be impressed enough to listen, but will still demand single combat to resolve the conflict of Honor.

This combat can be resolved in the ship's gymnasium. There are very few rules. The character who first submits will be the loser; the fight is without weapons, and continues until one character submits. The Captain may freely submit at any time. Judge the Gorn leader's submission by making a percentile dice roll at the end of each combat round. The base chance for the Gorn to surrender is 10%, increased by one every round (because the Captain is still fighting) and by the number of damage points taken in that particular round. Judge the combat results using the normal combat system.

The major risk of this fight is not so much physical damage, but, instead, the results of submission on the Captain's part. Gorn custom holds that the loser of such a test of strength submits in *all things* to the winner. If the Captain fights and loses, the Gorn will no longer be upset, but they will expect the Captain to follow their instructions to the letter. Should he attempt to resist them at a later time, the harm will be far worse than the original unfortunate situation. Lt. Price should be sure to warn to Captain of these consequences before he becomes irrevocably committed to this course.

If the Gorn submits, it will be most likely in recognition of the Captain's bravery, rather than through actually being beaten. After the combat, S'slee will place himself entirely at the Captain's disposal for the remainder of the adventure.

It should be noted that the outcome of a combat will end in a highly unstable situation whomever is the winner. Star Fleet cannot afford to have an officer expected to obey a Gorn, and S'slee would have to resign his diplomatic position if he, in turn, were subject to a Human. An escape valve does exist that can be called into play if the need arises; a master can release the bonds of Honor that bind an underling to him. Thus, if the Gorn is impressed with the Captain's handling of the rest of the adventure, he can release the Captain from submission at the end of it. If the Captain won the fight, Lt. Price will advise him to free the Gorn, for S'slee is the foremost advocate of the peace conference in the Alliance, and his withdrawal from the embassy would be a great blow to the Federation cause.

These solutions should be held back through most of the game, just to keep the players concerned. S'slee would save the move until his purposes were fulfilled, while Price would have to do a great deal of research to verify that this was a permissible part of the Warrior's Code.

## THE DERELICT

If the Captain orders *Hastings* to aid of the Gorn ship, the destroyer will be able to reach the scene within half an hour of picking up the distress call and altering course.

When the Gorn ship comes into first sensors contact, it proves to be drifting near the edge of an uninhabited system's asteroid belt. No other targets are within sensor range. Scans of the Gorn vessel show it to be without power, and no life forms are on board. Though it is apparent that ship-to-ship combat occurred, hull integrity of the vessel remains intact, and a standard atmosphere remains inside. There are no answers to hails made on any frequency.



It is not unlikely that the players will be suspicious enough to consider the possibility of an ambush. If the Science Officer announces that he is scanning the asteroids with particular care at any time prior to the appearance of the ambushing Gorn vessel, the player should be required to make a Skill Roll against the character's rating in *Starship Sensors* with a penalty of -20 to the rating. If the roll is successful, an anomalous reading will turn up, one that isn't quite normal for an asteroid. It, of course, is a camouflaged Gorn ship drifting among the asteroids, its power systems shut down to an absolute minimum, hoping to be completely unnoticed. If the *Hastings* approaches, the camouflaged ship will attack, as described in **The Starship Combat**, detailed below.

If the Science Officer fails to detect the camouflaged ship or if the *Hastings* does not investigate the anomaly, the Gorn raider will attack while the derelict is being searched closely.

### THE BOARDING PARTY

A boarding party is the only way of learning more about the derelict. The Captain may decide the composition of the party, but it certainly should include a Medical Officer, an Engineering Officer, and a Security team. S'slee, his aides, and Lt. Price will also want to go, and turning them down could give rise to bad feelings, as before.

Deck plans of the derelict, the Gorn equivalent of the Federation's Mission-class Courier, are provided in a separate section of this booklet; use them after the boarding party beams aboard.

It is immediately plain that fighting took place on board the courier as well. Scorch marks show the effects of energy weapons fire on individuals, equipment, and bulkheads.

Dead Gorn are found sprawled on the deck or behind furniture, some clutching hand weapons. There are a total of eight bodies on board, including one found hunched over the ship's communications console, the luckless individual who sent the final distress call.

If S'slee is along, he will recognize the body, saying "I thought it was his voice..." and making several formal gestures over the body which Lt. Price will interpret to the Federation party as being ritual indications of sorrow, grief, and



rage. The dead Gorn is a childhood friend of S'slee's who was one of those who joined him in his defection from the actionist party, and S'slee vows vengeance, for the friend had many claims of honor upon S'slee.

The Gorn aide Slas'sarn will begin once again attempting to convince his leader that the courier met its fate at the hands of the Federation. However, should a tricorder analysis be made of any of the blast marks, a successful Skill Roll against a rating in *Starship Weaponry Technology* or *Personal Weapons Technology* will prove that the blasts are characteristic of Gorn blasters, rather than any Federation weapon. This is not entirely conclusive, but will serve to quiet the aide for a time.

At this point in the boarding party's investigations, the *Hastings*' sensors pick up a target that has suddenly powered up. Navigation will show it on an intercept course with the Federation destroyer.

#### THE STARSHIP COMBAT

If the hidden ship is able to launch its ambush or if the *Hastings* approaches it while investigating the sensors anomaly, a starship combat will result at sublight speed. The gamemaster should lay out the *Starfield Mapsheer* and counters for the *Hastings* and the unknown attacker, which is only 8 hexes away from the *Hastings*. A counter should be laid out nearby for the Gorn courier, and a scattering of blank counters should be used to indicate asteroids.

As soon as the deployment is made, the senior officer on the Federation ship's bridge may issue orders regarding ship status for the first combat turn.

It should be noted that the initial deployment of the attacker puts it in range of *Hastings*. A wise captain would raise shields immediately. If this is done, however, the boarding party aboard the courier cannot be beamed back aboard, because as long as shields are up, the destroyer's transporters cannot be used. Thus, the Captain (or senior officer present, if the Captain is with the boarding party) must choose between abandoning the boarding party (temporarily, at least), or exposing *Hastings* to attack.

The starship combat that ensues should be resolved normally, with *Hastings* opposing a single Gorn cruiser. The Gorn ship is under the control of the gamemaster. Its commander has Skill Ratings in *Starship Combat Strategy/Tactics* of 78, and its crew's Efficiency Rating is 68.

If some bridge personnel are with the boarding party, NPCs representing junior personnel may be used to man those positions. Player characters may double up duties to play these individuals. For instance, if a character has the Chief Medical Officer — who has nothing at all to do in the starship combat — he or she may run an NPC on the bridge crew for the duration of the combat.

Characters in the boarding party may elect to sit on the sidelines and watch, in which case those players may also run NPCs aboard *Hastings*. They also may choose to undertake a more active role. It is possible to power up the damaged courier and get her back into at least partial service, thus giving *Hastings* an unexpected backup in the battle.

Several of the damaged courier's shipboard systems must be restored to operation before this can be undertaken. Basically, each ship's console requires repairs. Repairs are carried out by making Skill Rolls against the ratings in the technology skills appropriate to the console. One such Skill Roll is allowed for each character in the landing party (including the Gorn characters) every combat turn, beginning with the second turn after the camouflaged ship attacks.

The specific rolls required are listed for each panel damaged; each is made with a penalty of -25 unless one of the Gorn officers is working on or assisting in the repair of the console. If a console has not been repaired, it cannot be used. Thus, if the Navigation Panel is still inoperable, deflector shields may not be raised. This will not prevent other

systems from functioning, but, in some cases (Engineering, especially) repairs will be crucial to overall success.  
*Engineering* — Astronautics (Starship Engineering)  
*Navigation* — Deflector Shield Technology  
*Helm* — Starship Helm Operation  
*Weaponry* — Ship's Weaponry Technology  
*Sensors* — Starship Sensors  
*Communications/Damage Control* — Communication Systems Technology

Once the ship is powered up, the boarding party man the ship's command control panels (provided in this booklet) and participate in combat. Communications with *Hastings* is automatic, because the Federation communicators will work. This allows coordinated action between the two vessels. The *Hastings*' Communications/Damage Control Officer is responsible for keeping the channel open; should that officer be put out of action, communication is temporarily out.

The gamemaster should stage this battle carefully. When the Gorn cruiser is first sighted, decisions should be called for immediately from both groups of player characters, with little communication. If repairs to the courier are to be attempted, it takes one turn to issue those orders and get everyone to work. At the beginning of the second turn, rolls may be made for repair. When the Engineering Panel is operational, half normal power is available. Other systems are restored to normal once repairs are made. The ship has suffered 2 points of superstructure damage.

Any time a Skill Roll for restoring operation fails by fewer than 10 points, the gamemaster may permit an immediate Saving Roll against LUC to complete the task. This is a discretionary call; the object is to permit the characters to get the courier into operation in time to play a part in the developing battle. Thus, a little bit of fudging on the gamemaster's part may be used to permit the goal to be achieved, but the players should be sweating a bit before the battle is over. (The general atmosphere of this situation should be drawn from the *STAR TREK* episode *The Doomsday Machine*, in which Kirk, Scott, and a handful of others attempt to repair the damaged *USS Constellation* so it can assist the *Enterprise* against a giant, robot planet-wrecker. This episode can be an excellent guideline in establishing the feel of the action aboard the Gorn courier.)

The gamemaster should have the Gorn attacker break off the attack if it suffers more than three internal hits. It is integral to the situation that the cruiser live to fight another day, so a hasty departure is required. *Hastings* should be more than a match for the Gorn, so there is little likelihood that the *Hastings* would lose the engagement. If so, the adventure is, of course, over, and the cause of peace with the Gorn shattered completely. Perhaps future adventures could deal with the *Enterprise* or other ships involved in the Frontier War!

#### AFTERMATH

Assuming that *Hastings* does indeed defeat the Gorn cruiser, pursuit will not be practical. If nothing else, it will be necessary to pick up the boarding party, and even in that time, the fleeing cruiser will be long gone.

The characters should take stock of their situation following the battle and make a few quick decisions. The Gorn Ambassador will desire a brief meeting with the Captain and other senior officers for this purpose, even if the players do not want to discuss their situation themselves.

Slas'sarn, the antagonistic Gorn aide, will have undergone a bit of a change during the battle, becoming the very essence of cooperation. All of his information indicates that the renegades only have one cruiser, and, now that it has been badly damaged and forced to flee, the renegade threat is much reduced. S'slee, will agree with this assessment, and feel that his mission will now be fairly easy to complete.

Slas'sarn wishes to take two of the Gorn bodyguards, repair the warp drives, and proceed with the courier back to Clanhaven. Notification of the Alliance embassy concerning the fate of the courier and the battle with the cruiser is important, and Slas'sarn feels it should be conveyed in person and in detail, rather than via subspace radio.

If the gamemaster has made Slas'sarn enough of a pain in the neck in the past, the players should be glad to let him go. However, it is up to the Captain to make the final decision. It may be that he will desire the use of the courier for carrying out the rest of the mission, or the players may suspect Slas'sarn and be unwilling to let him out of their sight. As always, though, denial of the Gorn request can be a tricky business, requiring quite a bit of Negotiation/Diplomacy skill to carry off properly.

If the decision is made to use the courier for any purpose, it will take 1D10 hours to oversee repairs, after which the courier may be used. Only if it is to be abandoned, or pulled by a tractor beam, can the delay be avoided.

Slas'sarn's actual purpose is to further delay the destroyer, hoping to win time for the fleeing cruiser to make some repairs and ready a trap at Maltharin II. It is necessary to his plans that he not be aboard *Hastings* when the trap is sprung, and the courier offers a convenient method of accomplishing this. Should Slas'sarn be denied use of the courier, he will continue as part of S'slee's party. He will continue to Maltharin II, biding his time for a chance to betray his comrades and set events in motion as originally planned.

The final decision is still the Captain's to make. The gamemaster should be prepared to go along with that decision, yet still cause events to move towards the end as set forth in the rest of the adventure.

## EVENTS AT MALTHARIN II

The following information is for the gamemaster's use, and should only be revealed to the players as they find out pieces of it. Information on the planet itself that can be found in the *Hastings'* library computers is given in the section **Background Information**.

Maltharin II has indeed been the primary base for the Gorn renegades since they began their attacks on Federation shipping. The dilithium cracking plant has not been restored to normal operation, but warehoused crystals have been recovered by the renegades to augment their power reserves. The squadron has also made use of base equipment, tools, stores, fabrication units, and the like to supplement their own comparatively meager supplies, since they have been forced to operate without the sanction or support of the Alliance government. The outpost has also proven a good, secure location for R&R facilities, medical recovery services, and quarters for personnel not used aboard the squadron's ships.

Prior to the arrival of the *Hastings*, the Gorn pulled all personnel off the planet except for a detached force of trained combat troops. These have been placed in various underground buildings, where sensor scans will be less likely to penetrate. The soldiers are part of an ambush set up to capture any party beamed down to the planet (hopefully, S'slee and his retinue); the operation is set up to trap the *Hastings* into providing the grounds for a major diplomatic incident that will trigger the war the actionist renegades desire.

More details on the Gorn outpost are provided in a separate section of the booklet, including a map and a description of specific places of potential interest.

### THE HASTINGS IN ORBIT

When the *Hastings* reaches the Maltharin II system, the stage is set for the final confrontations of the adventure. Whereas parts of this adventure have been linear in nature, progressing from one point to the next with the players

having little effect on the action, what follows is not. The exact course of events will depend largely upon the precise decisions made by the Captain from this point on. The gamemaster should attempt at all times to preserve the players' freedom of choice and to allow them to control their own actions. To this end, the results of most of the more obvious possible decisions are set forth on the pages that follow. Where players wish to do something radically different, and not covered here, the gamemaster must attempt to come up with solutions which permit the players to follow the course of action they specify, yet still allow events to move pretty much as anticipated in the text. Where possible, gamemasters should not put themselves in the position of forbidding some specific action. On the other hand, neither should players be able to completely short circuit the intent of the adventure by some outlandish or completely unconventional set of maneuvers.

Once the *Hastings* assumes standard orbit, the Science Officer may make sensor sweeps of the region, including the Gorn base. The sensor scans will reveal the following facts automatically:

1. There is no sign of any other vessel in nearby space and there are no convenient asteroid belts in the neighborhood to hide unfriendly Gorns.
2. There is no sign of higher forms of life on the planet's surface, including the area of the outpost itself.
3. There is a 5,000-metric-ton ship at the base landing field; it is a Gorn courier ship. If the play included answering the distress call, the scan will reveal that the ship is the same type as the derelict.

If he desires, the Science Officer may make additional scans of the base. He will gain new information about the ambush force there if he makes successful Skill Rolls against his rating in *Starship Sensors*, modified as indicated below.

1a. *No modifier, and only if Slas'sarn was permitted to "return to Clanhaven" in the courier ship.* The small ship at the landing field is damaged, probably from starship combat.

1b. *A second roll, with a -20 penalty.* The courier ship is the *Sess'lessar*, the vessel Slas'sarn was permitted to take.

2. *No penalty.* There are underground buildings on the base.  
3a. *-40 penalty.* There are confused readings of uncertain life forms in several of the underground buildings. No clear idea of the number or nature of these life forms was scanned, thanks to the natural protection afforded by the planet's surface.

3b. *A second roll, with a -60 penalty.* The life forms are Gorn.

4a. *-20 penalty.* Power sources are in operation in the underground buildings.

4b. *A second roll, -40 penalty.* There are fixed power sources that seem to be running standard life support and maintenance equipment.

4c. *A third roll, -60 penalty.* There are some portable power sources, but their use is not determinable.

### THE LANDING PARTY

S'slee appears on the bridge, clad in a blue tunic that proclaims his role as an envoy. He greets the Captain formally, and declares that he wishes to resolve the mission as quickly as possible. He states that he and his retinue must beam down to the outpost at once. If any renegades are there, S'slee will deliver the message entrusted to him. The formula of S'slee's message indicates that Federation ships will take action against the renegades, with the full sanction of the Alliance government, if the renegades do not submit to the will of the Autarch and the council. If no one is present, the Gorn can determine whether or not the facilities have been used recently.

Federation representatives are required to beam down as well, to show that the Alliance and the Federation stand together. Lt. Price is to be one representative, but two more senior officers and a retinue of 'bodyguards' should be sent

as well. Composition of the Federation landing party is up to the Captain.

The players will probably be rather worried about beaming a party down into an ambush. S'slee will attempt to reassure the *Hastings* crew. He states that while he must be cautious, custom demands he be given a hearing. He further assures them that once he invokes a certain ritual formula, he will be safe from harm throughout his mission as will all those with him. Honor demands that they be kept from harm.

S'slee freely proclaims that he sees no great hope of success in convincing the actionists to surrender. As he says to the Captain, "When this voyage began, I genuinely felt we could reason with them. The fate of the courier, however, argues otherwise, and if honor did not impel me to fulfill my mission, I would sooner destroy them than treat with them.

Thus could my obligations to Grossigg, my dead comrade, be satisfied. But our Ambassador has placed a demand of Honor upon me that must be carried through, and to do so I must have your cooperation as well, Captain."

The Captain really has little choice in this matter, since it is, after all, the mission he was ordered to undertake. His main decision at this point revolve around who to send with S'slee. One option he could consider would be to send down an extra landing party, separate from S'slee's, to keep an eye on the first group. This is perfectly allowable, but only if the players think of it!

Ideally, either the Captain or the First Officer should accompany the landing party for proper protocol, if nothing more. (*STAR TREK* episodes notwithstanding, probably both the Captain and the First Officer would not take part, one staying behind to run the ship.) Another senior officer should be chosen, and the 'bodyguards' should be security personnel. The Human party and the Gorn party should be of equal size. If Slas'sarn is present, four crewmen and a security officer would be appropriate; if he is not present, an officer and 3 guards should be sent. Lt. Travers will volunteer to head up the security detail (The Captain may decide to turn him down, for obvious reasons, but he really does deserve a chance to prove himself.) Lt. Price will be one of the officers.

#### BEAMING DOWN

The landing party accompanying S'slee numbers 10 to 16 — two or three separate groups to transport. Emergency transporters could be used, if desired, either for beaming down or recovering the landing party, but this courts possible disaster if the Skill Roll against *Transporter Operation Procedures* fails. Use of the regular transporter will require beaming in shifts. Though use of several separate transporter rooms simultaneously is possible, because of power limitations in the transporter systems, simultaneous use of 2 or more ordinary transporters is equivalent to using the 22-man emergency transporter and Skill Rolls must be made for each separate group. If the normal transporters are used, it will take a short but significant length of time to get all members of the party beamed down, with a similar time for recovery. This could pose a problem if there is a need to evacuate in a hurry, a problem further complicated if an additional landing party were also present on the surface.

The coordinates S'slee gives to the transporter technician puts the landing party down in the midst of the military installation, near the landing field and next to the entrance

to the shield generator station, the largest above-ground structure in this portion of the outpost. There is no sign of life around at this point, but, if the Gorn courier is indeed the Sess'lessar, this fact will be discovered at this time if it was not discovered by sensors Skill Rolls.

#### THE AMBUSH

The section on *Hints For Play* gives techniques for playing out this section and the next, allowing the action on the ground and the action aboard the *Hastings* to be played out by all the players, yet retaining the suspense generated by the ambush. The following information pertains to those characters who are in the landing party; none of the characters aboard the *Hastings* will know this information unless and until the two groups are reunited.

A few minutes after the last member of the landing party

has been beamed down, trouble begins. First, communication with the ship is blocked suddenly by heavy jamming; second, deflector shields suddenly come up around the base. The landing party can neither communicate nor be beamed up. Moments later, Gorn soldiers appear from various entrances to underground buildings.

S'slee at once steps forward, preparing to invoke his rights as an envoy. His speech begins, "I, S'slee, speak to you in the name of..." but it gets no further. Several Gorn soldiers open fire on the landing party with heavy energy weapons of an unfamiliar pattern.

S'slee is unable to complete his speech, and all members of the landing party are quickly rendered unconscious by their Gorn attackers.

The weapons are Gorn sonic stunners, a non-lethal weapon used for crowd control and other instances where permanent damage is not to be inflicted. The sonic stunner is a heavy, clumsy weapon, similar in relative size to a 20th-century submachine gun or small carbine. Weapon stats are given below:

#### Gorn Sonic Stunner (P)

150 pts non-lethal damage  
Power = 30  
Graze = 20  
Drain = 2

Effects are similar to a phaser on Standard stun setting.

#### THE HASTINGS REACTS

The following information will be known only to the characters who remain aboard the *Hastings*. None of the characters in the landing party will know what happened there unless and until the two groups are reunited.

On board the orbiting destroyer, the sudden bout of radio jamming and the appearance of the station's deflector shields come as a complete surprise. In addition to normal communications, subspace radio channels also are blocked by transmissions from the planet. Jamming is removed from the ordinary radio channels a short time later, but the landing party can't be raised then; the subspace channels remain jammed.

A few minutes after normal communication is restored, the Communications/Damage Control Officer discovers that one subspace channel is not being jammed, but a transmission is being sent out on that channel from the Gorn base. The destroyer is only picking up leakage from a shielded,





tight-beam message. The Comm Officer may make a Skill Roll against his/her rating in *Communications Systems Operation (Starship Communications Procedures)* in an attempt to tap into the message.

If the roll is successful, the full message, including visual signal, is picked up. A familiar image appears on the screen — Slas'sarn. His message, in full, is: "This is Officer/Leader Slas'sarn, speaking for S'slee, Captain/Leader. The cruisers *Hssig'ssee* and *Sl'sasigri* are summoned off station. Make maximum speed to this base. Now that our Captain/Leader has been delivered safely, you may destroy the orbiting Federation ship, if necessary. Our estimates make your ETA 45 minutes from now if you proceed at maximum speed. Slas'sarn, speaking for the Captain/Leader, ending message."

If the roll is unsuccessful, only parts of the message are picked up. The following fragments give the best sense that can be gathered after translation and computer enhancement has rendered the signal as clear as possible. "... Speaking for S'slee ... cruisers ... maximum speed to this base ... destroy ... Federation ship, if necessary ... make your ETA 45 minutes ... Slas'sarn ..." Because the characters aboard the *Hastings* know nothing at this time about the actual fate of the landing party, and because, as far as they can tell, S'slee and his embassy have betrayed them, the commanding officer on the bridge is forced to make a painful decision. He must choose whether to attempt a of rescue the Federation landing party, thus risking an encounter with Gorn cruisers, or to abandon the captives and try to get word of S'slee's defection back to Admiral Mendez or other Star Fleet officials.

If the decision is made to leave, the *Hastings* can withdraw successfully before Gorn ships arrive. This removes the destroyer and all the characters aboard her from the game, and only the fate of the captives need be considered. This is exactly what the Gorns desire. Although it probably is the most logical decision, it is hardly in the best *STAR TREK* tradition.

If a rescue is chosen, the players should realize they are operating under a time limit, and against the odds. Nothing — neither transporter beams nor a shuttlecraft — can penetrate the outpost's deflector shields while they are up. This means that the shields must be knocked down, a far from easy task in the 45 minutes available before Gorn reinforcements are due to arrive.

The planet-bound outpost has very strong shields, and almost unlimited power to operate them. The paragraphs below give the system for judging the effectiveness of such shots.

Range from the *Hastings* to the target is automatically considered to be 14 hexes, due to the effects of firing through atmosphere. Since the base has no weapons with which to fire back, as many attacks may be made in a turn as desired; also, when firing at the planet, all three banks of phasers can be brought to bear simultaneously.

The *Hastings* cannot produce more than 18 points of damage in any one attack — insufficient to penetrate the shields, which can be raised to a total of 20 points. Photon torpedoes cannot be fired into atmosphere successfully. Even if a shield could be penetrated, it would be very difficult to damage the shield generators, since backup systems and extra power sources will make reestablishment of damaged shields comparatively easy. This would ordinarily make it a complete standoff.

There are several ways around the problem that may be attempted, however. Both involve setting up the phaser banks to temporarily channel more power than usual, creating an overload that is extremely dangerous to the ship; this solution may be proposed by either the Engineering Officer or the Helmsman in charge if the players do not think of it themselves. The system for judging this is given in the

section on **Overload!** below.

When the phasers are given more power, phaser shots from the *Hastings* will then penetrate the shields, doing damage on the ground, and possibly even to the shield generator. With the shield generator damaged, a second party can be beamed into the outpost or the landing party can possibly be beamed aboard. A two-pronged attack also is possible. If the shuttlecraft is landed near but outside of the shielded outpost or if personnel are beamed down outside the shielded outpost, attempts to penetrate the base can be made any time hits cause the shields to be penetrated. These possibilities are covered in the sections on **Turkey Shoot** and **Running The Gauntlet**.

Once a landing party penetrates the base, the options open to them are similar to those outlined for captive player characters in the section on **Behind Enemy Lines**.

#### **OVERLOAD!**

To set up an overload, the Engineer Officer and the Helmsman in charge must use their skills. The players must make successful Skill Rolls against their characters' ratings, the Engineer against his rating in *Astronautics (Starship Engineering)* and the Helmsman against his rating in *Starship Weaponry Technology*. One Skill Roll is allowed every 5 minutes, until both characters are successful at the same time. For this 5-minute period only, phaser power can be increased by 1 damage point per phaser, so that they would generate 24 damage points rather than 18.

To penetrate the shields of the outpost, ship phasers must have a lethal setting, not a stun setting. Thus, firing on the shields does pose a certain risk to the captives on the surface, and this should be taken into account before orders to fire are issued.

Because of the critical nature of the overload, the phasers may only fire this high-power burst once every 5 minutes instead of the usual once per 10-second game turn. Furthermore, there is a chance of damaging the phasers with every shot. For this reason, overload setups are rarely used in starship combat.

Every time the phasers are fired, hits are automatic as outlined in the section **Turkey Shoot** below. After hits and damage are figured, however, the Helmsman must make Skill Rolls against his rating in *Starship Weaponry Operation* (or *Strsh. Weap. Tech.* for characters created using the system in the first edition of *ST:RPG*). A roll must be made for each bank of phasers firing.

If the roll is successful, the systems are not damaged by the shot and the entire process can be repeated in the next 5-minute interval. If, however, the roll is unsuccessful, the overloaded phasers are out of action just as they would be in starship combat, and additional rolls are made as though the *Hastings* had suffered a normal hit in the same area as the damaged weapon bank. Here is a good place for the gamemaster to allow the Helmsman to make an immediate Saving Roll against his LUC score if he fails his Skill Roll. Thus, it is possible that the *Hastings* will be damaged before the two Gorn cruisers arrive.

#### **TURKEY SHOOT**

A stationary planetary target would pose no problems at all, as shown by the fire from the *Enterprise* in the episodes *The Apple, Bread And Circuses*, and *A Piece of the Action*. Thus shots from the destroyer's overloaded phasers are automatic hits that penetrate the outpost's deflector shields. The damage done by the shot is resolved by rolling 1D10 and consulting the Outpost Damage Table below. Following the table, each of the possible outcomes is described.

<i>Outpost</i>	<i>Damage Table</i>
1	Shield generator station damaged (50%)
2	Courier ship hit (60%)
3-5	General surface hit (20%)
6-10	No damage

The number in parentheses after several of the entries determines casualties. First, the remaining enemy forces in the area hit are reduced by the percentage indicated. Second, each friendly character has that chance of being hit if he is within the field of fire; roll percentile dice. If the character is hit. Apply damage as in normal combat, with the phaser doing 4x normal damage. Likely the character will be dead unless the gamemaster allows an emergency Saving Throw against LUC for a graze.

#### Damage Effects

**Shield Generator Station Damaged:** The shield generator is damaged. There is a 40% chance that the shields will be reestablished in the next 10-second round, with a +10% chance for every round thereafter. The next time the shield generators are operative, they will be less effective than originally. Roll 1D10 to find out how much less. There is a 50% chance for casualties to anyone within the shield generator building.

**Courier Damaged:** The courier ship takes damage as in starship combat. The amount of damage is determined by how much penetrated the shields. Roll a separate damage location for every 5 points of damage sustained. There is a 60% chance for casualties to anyone inside the courier.

**General Surface Hit:** No real damage is done except to characters who happen to be outside. There is a 20% chance for casualties for anyone outside the buildings or the courier.

It is possible to be more selective in targetting, but firing on shields tends to dissipate phaser fire somewhat, making selectivity more difficult. To better target the phasers, the Science Officer can attempt to fine tune the targetting sensors just as the Helmsman fires. The characters must make Skill Rolls, the Science Officer against his rating in *Starship Sensors* and the Helmsman against his rating in *Starship Weaponry Operation (or Technology)*. These Skill Rolls are made with a penalty modifier equal to the shield value at the time of firing. If either or both rolls are not successful, then no penalty results. If, however, both rolls are successful, one target may be selected from the table for the attack. This would allow the *Hastings* to concentrate on bringing the shields down to a manageable level so that overload tactics need not be tried too often.

#### BEAMING THROUGH THE GAP

A landing party may be beamed down into the outpost at the beginning of any round in which the shields are not up, but there is real danger in this, for it takes time to accomplish the beaming. It takes one round to determine that the shields have failed. It takes a second round to dematerialize a landing party waiting on the transporter pad with the controls all set. It takes a third round to rematerialize the landing party on the surface.

If the shields go up in the first round, the process may be aborted with no ill effects.

If the shields go up in the second round, the Science Officer can make a Skill Roll against his rating in *Starship Sensors* to notice this in time to warn whoever is operating the transporter. Then, the transporter technician or the player character operating the transporter must make a successful Skill Roll against his rating in *Transporter Operation Procedures* to see if he can abort in time. If either of these rolls fail, then the characters in the transporter will be lost unless an emergency Saving Roll against LUC is made by whoever failed the Skill Roll.

If the shields go up in the third round, the characters in the transporter all must make an emergency Saving Roll against their LUC score. If the roll fails, their "molecules will be scattered all over the universe."

If the shields go up after the third round, the characters will be on the ground safely, even if the shields are re-established. They appear just outside the shield generator building, for this is the only setting that S'slee knows for certain.

#### RUNNING THE GAUNTLET

A certain amount of danger is posed for attackers who attempt to rush through the perimeter if the shield generator is downed by a successful hit. There is a good chance that the shield may be reestablished before the whole party is through. It will take characters three 10-second, combat turns to reach the shield boundary from a place of safety. (They don't want to be in the open while phaser fire is concentrated on the shield, for radiated energy from the attack could be very dangerous.) A fourth round is required to actually pass through the shield boundary. The shields are re-established as detailed above.

If the shields go back up before characters reach the boundary, they cannot be breached.

Should the shields go up as the characters are crossing the boundary, each must make a Saving Roll against LUC. If it succeeds, the character gets across the boundary in time and is safely (?) within the outpost. If the first roll is unsuccessful, a second Saving Roll against LUC is allowed. If it is successful, the character is still outside the shield when it comes up. If this second roll is unsuccessful, the character is caught in the shield force field as it comes back on, an effect identical to phaser disintegration. Probably, this fate should be reserved for security guards, secondary characters, and other extras, even if some fudging must be made to the dice roll. After all, the players do not know what kind of modifiers are being applied.

#### BEHIND ENEMY LINES

Plans of the outpost and of two particularly important buildings — the underground administration complex where the prisoners begin, and the shield generator building — are provided in this booklet, along with descriptions of various important locations shown on these maps. If additional maps are desired, the gamemaster should improvise as necessary.

The outpost shields can be intentionally shut down only from the generator building control room. Communications with the orbiting ship can be reestablished from the communications room in the same building, from the grounded courier ship, or via landing party communicators. Gorn soldiers captured by the characters are bound by honor not to cooperate, and will die rather than reveal information to the group.



Action should proceed using the *area scale*, with turns of 1-1/2 minutes in length. Indoors, multiply available APs by 10, and use the tactical scale maps to conduct searches and the like. Obviously, an encounter with

enemy soldiers causes the encounter to revert to *tactical scale* until it is resolved.

There are at least 50 Gorn soldiers at the outpost, enough to present a virtually unlimited supply for the characters to dodge. The gamemaster shouldn't attempt to handle 50 characters at a time. Encounters with the Gorn should be with small groups, as the soldiers are split up to go about their duties.

These general guidelines are left deliberately vague, since there is no way to anticipate precisely what players might decide to do. It is up to the gamemaster, using his awareness of the overall situation, to react to player moves to build the most interesting scenario.

#### ESCAPE

The members of the original landing party will recover consciousness after about 15 minutes, though there is no way for them to know this because their equipment has been taken from them. Thus, there is still about 30 minutes before the estimated arrival time of the Gorn cruisers, though they

won't yet be aware of this. The remaining time is sufficient for them to escape, if they put their minds to it, and to make a difference in the battle going on around them, if such is the case. There is even time to disable the shields, steal the courier, and totally if the *Hastings* has left them behind.

The prisoners will discover that S'slee and the other Gorn have been separated from the Federation party, which is confined in a large detention cell. Because the Gorn have not yet refined shield technology to the point where a detention force field is possible, the cell is guarded by more conventional means — a locked, reinforced steel door with guards posted outside. The party has, of course, been deprived of their usual equipment.

Various escape plans may present themselves. These will depend on many factors, and the gamemaster must judge the possibilities of success. The composition and equipment of the landing party would determine some possibilities. For example, a Vulcan could lure a guard in by a mind meld, as in the episodes *A Taste of Armageddon* and *By Any Other Name*.

Subcutaneous transponders could be converted into laser crystals through the use of skill in *Small Equipment Systems Technology*, as in *Patterns of Force*. Other possibilities are open to the imaginations of the players.

The gamemaster should offer at least one concrete chance of escape, even if the *Hastings* has departed. Checking on the prisoners' status by a guard, a visit by Slas'sarn to check taunt the "weak, miserable aliens," or some other opening which a group of captives could exploit to get out of the room. If they fail, it will be up to the *Hastings* to carry through the rescue. If they succeed, on the other hand, it will make for an interesting adventure situation.

Should the captives escape, their immediate options are to locate their equipment (phasers and communicators would both be useful), or to locate S'slee and the other envoys. The captives know nothing about the subspace radio message intercepted by the destroyer. Other options should open up later — an overheard conversation between two Gorns, interpreted by Lt. Price, of course) could reveal that the outpost shields are holding off rescue by the *Hastings*, giving rise to the possibility of trying to disable those shields, for instance.

The escapees' communicators and other equipment are being kept in the administration complex. Weapons also may be obtained from Gorn guards, most of whom are armed with blasters and a few (10%) with sonic stunners.

Every 3 minutes (2 turns), there is a 25% chance that the absence of the captives will be discovered and the alarm sounded, which will cause parties of armed Gorn to begin searching the outpost. Gorn encountered may be defeated before they have time to use an intercom or communicator to sound the alert, but this is unlikely. The gamemaster must use his discretion in setting up search parties and other encounters.

#### RESCUING S'SLEE

Despite the contents of the intercepted message, the Gorn envoy is not on the side of the actionists. He, too, is a captive, along with loyal members of his retinue. The message was part of the traitor Slas'sarn's deception described in the section on *Slas'sarn's Plan*. The first landing party will be unaware of the message, and so they should (according to Lt. Price, at least) consider rescuing the envoys. If S'slee and his loyal underlings are freed, they will join in the fight on the side of the player characters.

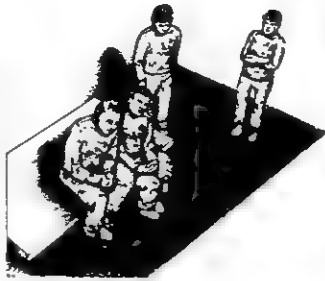

If the gamemaster has done a good job of presenting the Gorn leader to the players, they may well realize that such duplicity does not fit in with what they know of him, and so the characters aboard the *Hastings* may not be taken in by the false message. Should the players be convinced that he has turned on them, however, and thus leave him behind or, worse, attack him, things will turn pretty grim for the Federation. The gamemaster should try to arrange a confrontation in which S'slee's intervention offers convincing proof of his real loyalties. Again, however, it is necessary to adjust to the actions and responses of the players, and not to force them down any particular path.

#### BATTLE IN SPACE

Hopefully, escape and/or rescue attempts will be completed successfully by the time the two Gorn cruisers arrive. If the *Hastings* is still on the scene at this time, a battle ensues.

The Gorn ships are both cruisers, the *Hssig'ssee* and the *Sl'sasigri*. The *Sl'sasigri* is being commanded by the renegade Autarch, S'slee's father, who has a Skill Rating of 95 in *Starship Combat Strategy/Tactics*. His vessel has a Crew Efficiency Rating of 85. He commands the two ships as a squadron, which means, in effect, that both have a *Starship Combat Strategy/Tactics* Skill Rating of 95, as long as he is in the battle and the two vessels are in communication.

The *Hssig'ssee* is the same cruiser that lay in ambush in the asteroids near the courier 'derelict.' Its captain has a Skill Rating of 78 in *Starship Combat Strategy/Tactics*. His vessel has a Crew Efficiency Rating of 68.

The battle is resolved according to the rules for starship combat, with the exception of the special rules given below; if the **STARSHIP COMBAT SIMULATOR** published by FASA is used, the game should be conducted using **COMMAND & CONTROL** rules. The battle continues until the *Hastings* is destroyed or withdraws, or until the two Gorn cruisers can no longer continue fighting. Withdrawal of the Gorn ships is highly unlikely, given their urgent need to accomplish something now, before the Alliance and the Federation agree to unite and eliminate the threat to peace posed by this renegade group.

Every combat round, the Communications/Damage Control Officer of the *Hastings* may attempt to jam communications between the two Gorn ships instead of reducing crew casualties or controlling incoming damage. The Engineer must allocate 1 point of power for this purpose, and the Comm Officer must use his/her skill in *Communications System Operation* (*Strsh. Comm. Proc.* in the first edition). In the Skill Roll Phase of the game turn, the Comm Officer's Skill Roll is made as usual against his/her rating in *Communications Systems Operation*. Allocating additional power increases the chances of success; each additional point modifies the Skill Rating by +10. A successful roll indicates that communications were jammed, which causes each ship to use its own *Starship Combat Strategy/Tactics* rating, changing the tactical advantage balance somewhat. If an assistant gamemaster handles one of the two Gorn cruisers, both gamemasters could confer while jamming was unsuccessful, but could not do so if communications were jammed.

If S'slee is present on the *Hastings*'s bridge, he can supply the Captain with occasional insights into the way his father's tactical ideas may be put into effect on a particular combat round. After the gamemaster has decided how the *Sl'sasigri* will behave, but before the players have finished their allocations and plans, the gamemaster makes a secret Saving Roll against the average of the Captain's LUC and S'slee's INT of 62. If the roll succeeds, the gamemaster, as S'slee, will give the players some true information about the intentions of the Gorn vessels. If it fails, the information will be false. Because the roll was secret, the players are never sure if S'slee's estimates are correct. If S'slee is not present, no such rolls are made.



# MAPS

## THE OUTPOST MAPS

The information provided below describes the maps provided for the important buildings of the Gorn outpost.

### SHIELD GENERATOR BUILDING

#### SHIELD GENERATOR ROOM

This room contains all controls for the outpost deflector shields. A master control panel here can be used to raise or lower shields as desired. To operate the shield controls successfully, a character must make a successful Skill Roll against his rating in Deflector Shield Operation. This action takes 5 AP at the tactical scale, regardless of success. If a character is present who speaks the Gorn Language, the AP cost is reduced to 2 AP.

The panels can be destroyed if it takes 200 points of lethal damage or a phaser disintegrate beam. Destroying the

This is the largest above-ground structure on the outpost, and serves as a command center for the military installation. There will be 15 + 1D10 troops in the building at any given time, including technicians, guards, the outpost command staff, and Slas'sarn.

The building actually extends underground, but the lower levels are mostly filled with heavy equipment – power plants, generators, and shield mechanisms. The upper level is the only one mapped.

panel shuts down the system shuts down. This could happen accidentally, in the course of a fight.

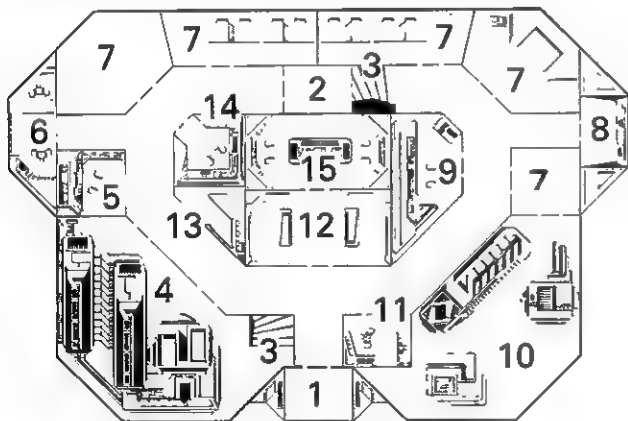

SHIELD GENERATOR BUILDING

- |   |                                  |
|---|----------------------------------|
| 1 Turbolift #1                                | 9 Computers                      |
| 2 Turbolift #2                                | 10 Heavy Equipment Storage       |
| 3 Stairs                                      | 11 Office                        |
| 4 Generator Equipment (Extends 2 levels down) | 12 Situation Room                |
| 5 Generator Monitor Room                      | 13 Security Station              |
| 6 Base Commanders Office                      | 14 Communications Room           |
| 7 Storage                                     | 15 Shield Generator Control Room |
| 8 Office                                      |                                  |

#### SITUATION ROOM

The situation room is the main command center for the outpost. Computer displays here project current tactical situations for ground, air, and space fighting. A screen will show the current positions of the *Hastings* and the two Gorn cruisers at all times, permitting the characters to determine how much time they have left before the renegade ships arrive.

#### BASE COMMANDER'S OFFICE

This office is being used by Slas'sarn. The landing party's weaponry and equipment is being kept here.

#### COMMUNICATIONS ROOM

Radio and subspace radio equipment is located here. A character who desires to operate the equipment must either have a Skill Rating of 10 in *Gorn Language* or he must make a successful Skill Roll against his rating in *Communications Systems Operation*. The subspace radio jamming equipment, set up to prevent *Hastings* from sending messages, can be put out of action if desired.

#### OTHER ROOMS

Contents of unidentified or undescribed rooms are up to the gamemaster, as is the placement of Gorn soldiers within the building. This should be done when player-characters first enter the complex, so that encounters may be regulated.

### THE ADMINISTRATION COMPLEX

Most of the floors of the complex are identical, and so the map can be reused for each of the complex's 7 levels. The complex was set up as the administrative facility for both the military base and the dilithium cracking plant; offices, conference rooms, and the like were set up for both military and civilian purposes.

#### THE ADMINISTRATION COMPLEX

- 1 Turbolift #1
- 2 Turbolift #2
- 3 Stairs
- 4 Detention Cells
- 5 Security Stations
- 6 Offices

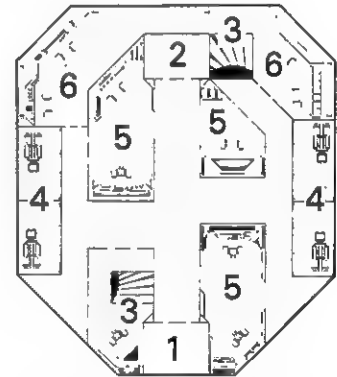

#### DETENTION CELLS

These rooms are equipped with reinforced doors, a minimum of furnishings, and little else of interest.

The gamemaster should choose the location of the cells where the Federation and Gorn captives are held; they should be on the same floor. Outside each will be posted 2 guards.

#### SECURITY STATION

These are offices converted by the troops into guard posts. Three Gorn are in each one.

#### TURBOLIFTS

Turbolifts respond to voice commands, in Gorn, only, of course! Lt. Price or any friendly Gorn can operate them.

A ladder is located between the two turbolift shafts.

#### OTHER ROOMS

Other rooms may be set up as the gamemaster desires. Most will be empty and unused, but some may contain Gorn troopers engaged in various activities.







# Weapons Systems Panel

## Firing Arcs

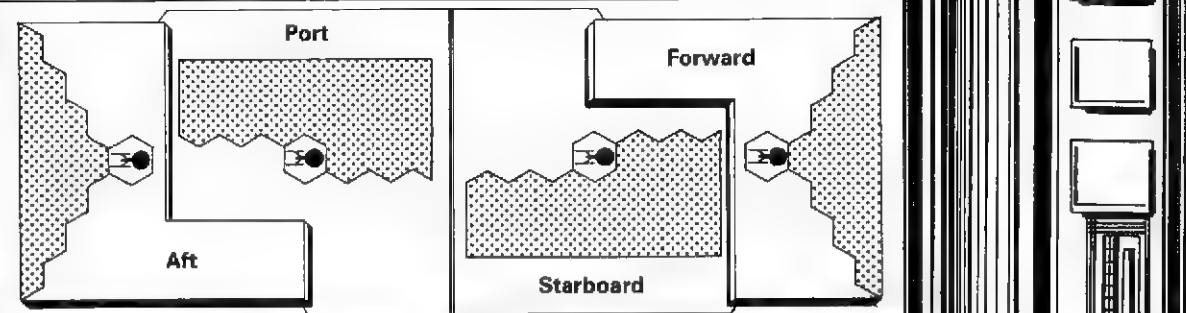

## Arcs Overlap

## Firing Charts

Range	Beam Weapon Type FH-4 Power Range 0-3		Beam Weapon Type Power Range		Beam Weapon Type Power Range		Beam Weapon Type Power Range		Missile Weapon Type FP-2 Power to Arm 1 Damage 6		Missile Weapon Type Power to Arm Damage	
	To Hit	Dam. Mod.	To Hit	Dam. Mod.	To Hit	Dam. Mod.	To Hit	Dam. Mod.	To Hit	Dam. Mod.	To Hit	Dam. Mod.
1	1-10	+2							1-10			
2	1-10	+2							1-9			
3	1-10	+2							1-8			
4	1-9	+2							1-7			
5	1-9	+2							1-6			
6	1-8	+2							1-5			
7	1-8	+2							1-4			
8	1-7	+2							1-3			
9	1-6	+1							1-2			
10	1-5	+1							1			
11	1-4	+1										
12	1-3	+1										
13	1-2	+1										
14	1	+1										
15												
16												
17												
18												
19												
20												
21												
22												
23												
24												

### Weapon Type and Bearing

Bank	Type	Power	F	S	A	1	2	3	4	5	6	7	8	9	10
1	Bank 1 Type FH-4	0-3	Ⓡ	Ⓡ	Ⓡ	DMGD	UN ARMED								
2	Bank 1 Type FH-4	0-3	Ⓡ	Ⓡ	Ⓡ	DMGD	UN ARMED								
3	Type	0-3	Ⓡ	Ⓡ	Ⓡ	DMGD	UN ARMED								
4	Bank 2 Type FH-4	0-3	Ⓡ	Ⓡ	Ⓡ	DMGD	UN ARMED								
5	Bank 2 Type FH-4	0-3	Ⓡ	Ⓡ	Ⓡ	DMGD	UN ARMED								
6	Type	0-3	Ⓡ	Ⓡ	Ⓡ	DMGD	UN ARMED								
7	Bank 3 Type FH-4	0-3	Ⓡ	Ⓡ	Ⓡ	DMGD	UN ARMED								
8	Bank 3 Type FH-4	0-3	Ⓡ	Ⓡ	Ⓡ	DMGD	UN ARMED								
9	Type	0-3	Ⓡ	Ⓡ	Ⓡ	DMGD	UN ARMED								
10	Type	0-3	Ⓡ	Ⓡ	Ⓡ	DMGD	UN ARMED								
11	Type	0-3	Ⓡ	Ⓡ	Ⓡ	DMGD	UN ARMED								
12	Type	0-3	Ⓡ	Ⓡ	Ⓡ	DMGD	UN ARMED								

1 DMGD UN ARMED ARM  
Type FH-2 Bearing Ⓡ

3 DMGD UN ARMED ARM  
Type Bearing Ⓡ

5 DMGD UN ARMED ARM  
Type Bearing Ⓡ

2 DMGD UN ARMED ARM  
Type FP-2 Bearing Ⓡ

4 DMGD UN ARMED ARM  
Type Bearing Ⓡ

6 DMGD UN ARMED ARM  
Type Bearing Ⓡ

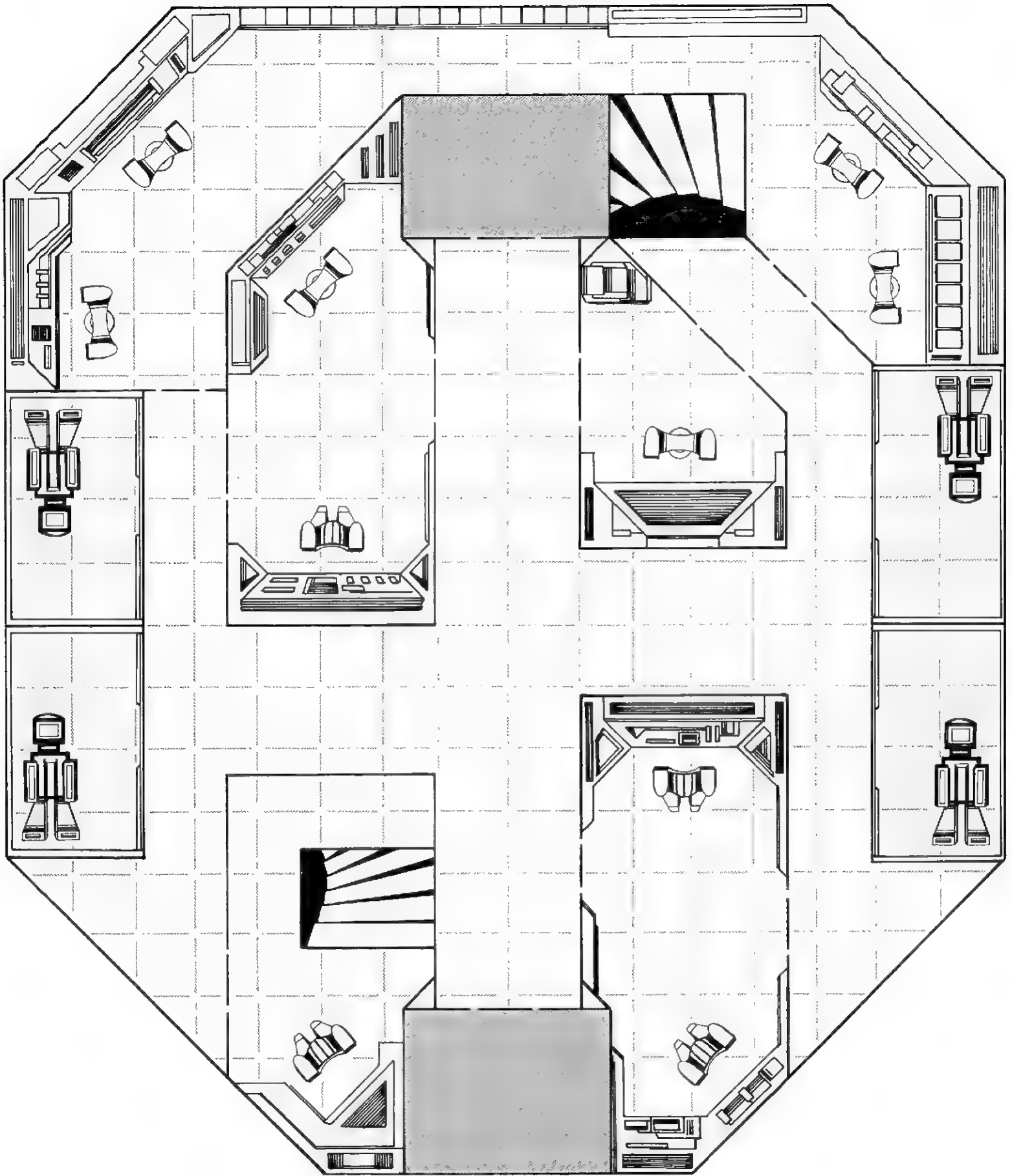

**THE ADMINISTRATION COMPLEX**

1 inch = 3 meters

# ENGINEERING PANEL

Impulse Engine

Type FWC

0	1	2	3	4	5	6	7	8	9	10	11	12	13	14	15	16	17	18	19	20	21	22	23
---	---	---	---	---	---	---	---	---	---	----	----	----	----	----	----	----	----	----	----	----	----	----	----

Warp Engine 1

Power

Type FIB

0	1	2	3	4	5	6	7	8	9	10	11	12	13	14	15	16	17	18	19	20	21	22	23	24	25	26
---	---	---	---	---	---	---	---	---	---	----	----	----	----	----	----	----	----	----	----	----	----	----	----	----	----	----

Warp Engine 2

Power

Type \_\_\_\_\_

0	1	2	3	4	5	6	7	8	9	10	11	12	13	14	15	16	17	18	19	20	21	22	23	24	25	26
---	---	---	---	---	---	---	---	---	---	----	----	----	----	----	----	----	----	----	----	----	----	----	----	----	----	----

Total Power Units Available

																																0	1	2	3	4	5	6	7	8	9
10	11	12	13	14	15	16	17	18	19	20	21	22	23	24	25	26	27	28	29	30	31	32	33	34	35	36	37	38	39	40	41										
42	43	44	45	46	47	48	49	50	51	52	53	54	55	56	57	58	59	60	61	62	63	64	65	66	67	68	69	70	71	72	73										

Power to Movement

Movement Point Ratio 2/1

																																0	1	2	3	4	5	6	7	8	9
10	11	12	13	14	15	16	17	18	19	20	21	22	23	24	25	26	27	28	29	30	31	32	33	34	35	36	37	38	39	40	41										
42	43	44	45	46	47	48	49	50	51	52	53	54	55	56	57	58	59	60	61	62	63	64	65	66	67	68	69	70	71	72	73										

Power to Weapons

																																0	1	2	3	4	5	6	7	8	9
10	11	12	13	14	15	16	17	18	19	20	21	22	23	24	25	26	27	28	29	30	31	32	33	34	35	36	37	38	39	40	41										
42	43	44	45	46	47	48	49	50	51	52	53	54	55	56	57	58	59	60	61	62	63	64	65	66	67	68	69	70	71	72	73										

Power to Shields

Shield Point Ratio 1/1

																																0	1	2	3	4	5	6	7	8	9
10	11	12	13	14	15	16	17	18	19	20	21	22	23	24	25	26	27	28	29	30	31	32	33	34	35	36	37	38	39	40	41										
42	43	44	45	46	47	48	49	50	51	52	53	54	55	56	57	58	59	60	61	62	63	64	65	66	67	68	69	70	71	72	73										



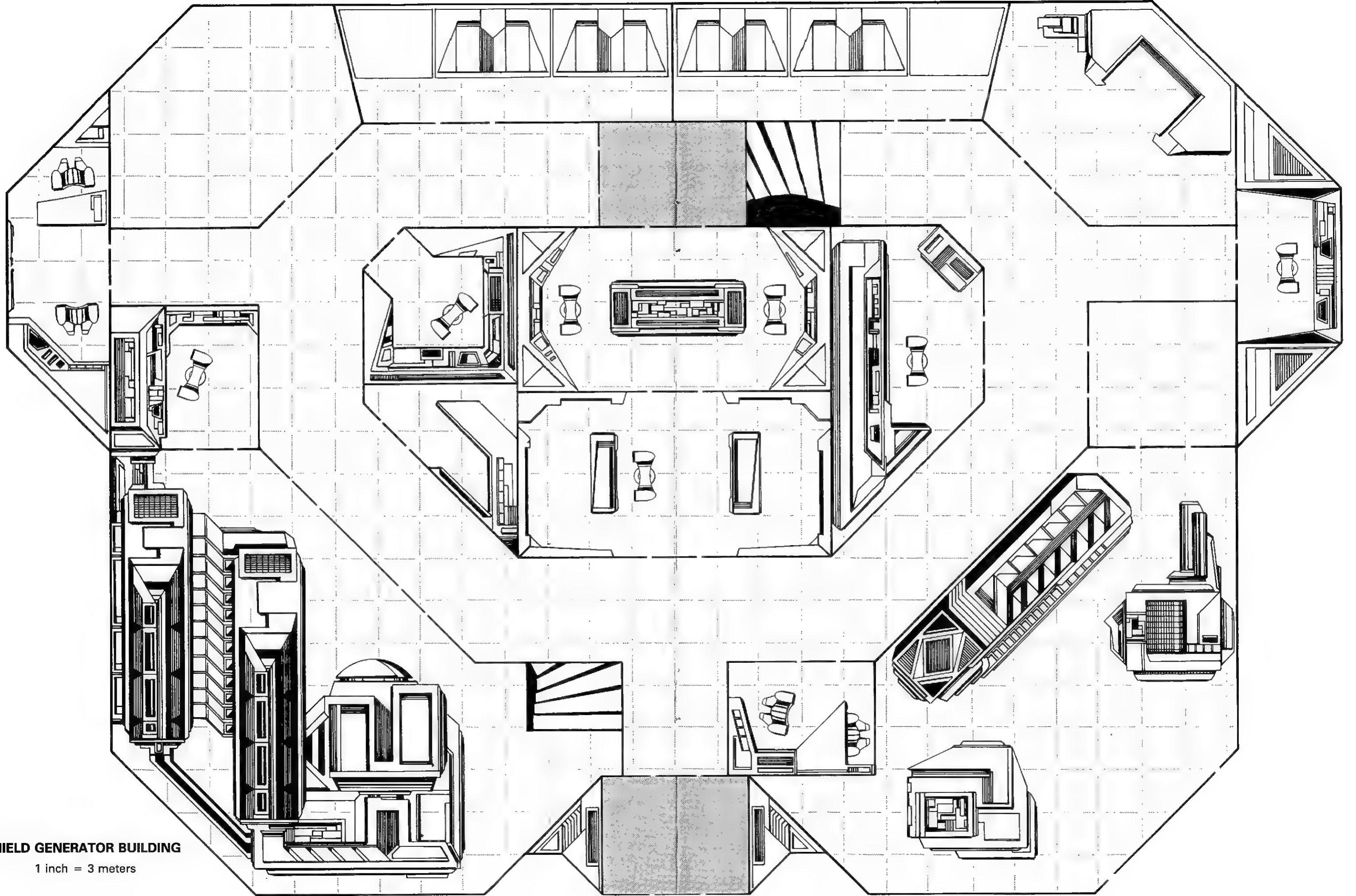

**SHIELD GENERATOR BUILDING**

1 inch = 3 meters

# DAMAGE CONTROL PANEL

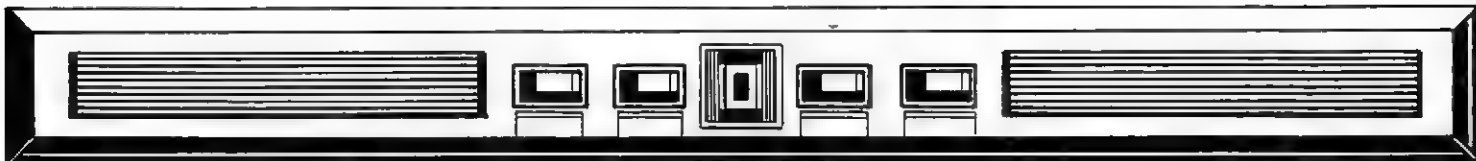
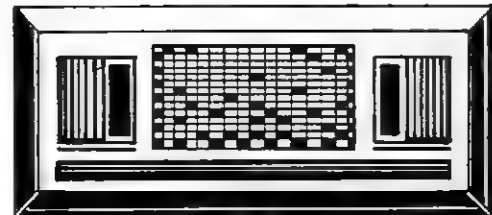
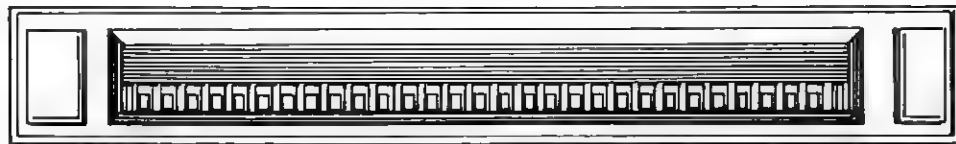

## Superstructure Damage

-10	-9	-8	-7	-6	-5	-4	-3	-2	-1	0	1	2	3	4	5
6	7	8	9	10	11	12	13	14	15	16	17	18	19	20	21
22	23	24	25	26	27	228	29	30	31	32	33	34	35	36	37
38	39	40	41	42	43	44	45	46	47	48	49	50			



Crew: 195

## Percent of Casualties

Tens <i>Die Roll Modifications</i>	0	10	20	30	40	50	60	70	80	90
	None	+1	+2	+3	+4	+5	+6	+7	+8	+9
Ones	0	1	2	3	4	5	6	7	8	9
Tenths	0	.1	.2	.3	.4	.5	.6	.7	.8	.9

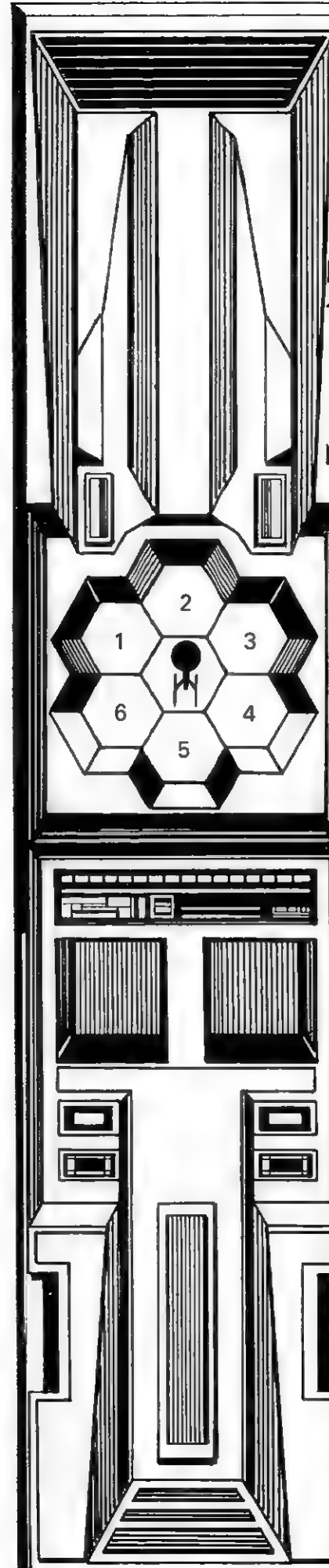

Deflector Shields					
Shield Type	FSC	Maximum Power	8	Shield Point Ratio	1/1
1	DMGD	Forward	2	DMGD	Aft
2	DMGD	Forward	3	DMGD	Aft
3	DMGD	Forward	4	DMGD	Aft
4	DMGD	Forward	5	DMGD	Aft
5	DMGD	Forward	6	DMGD	Aft
6	DMGD	Forward	7	DMGD	Aft
7	DMGD	Forward	8	DMGD	Aft
8	DMGD	Forward	9	DMGD	Aft
9	DMGD	Forward	10	DMGD	Aft
10	DMGD	Forward	11	DMGD	Aft
11	DMGD	Forward	12	DMGD	Aft
12	DMGD	Forward	13	DMGD	Aft
13	DMGD	Forward	14	DMGD	Aft
14	DMGD	Forward	15	DMGD	Aft
15	DMGD	Forward	16	DMGD	Aft
16	DMGD	Forward	16	DMGD	Aft

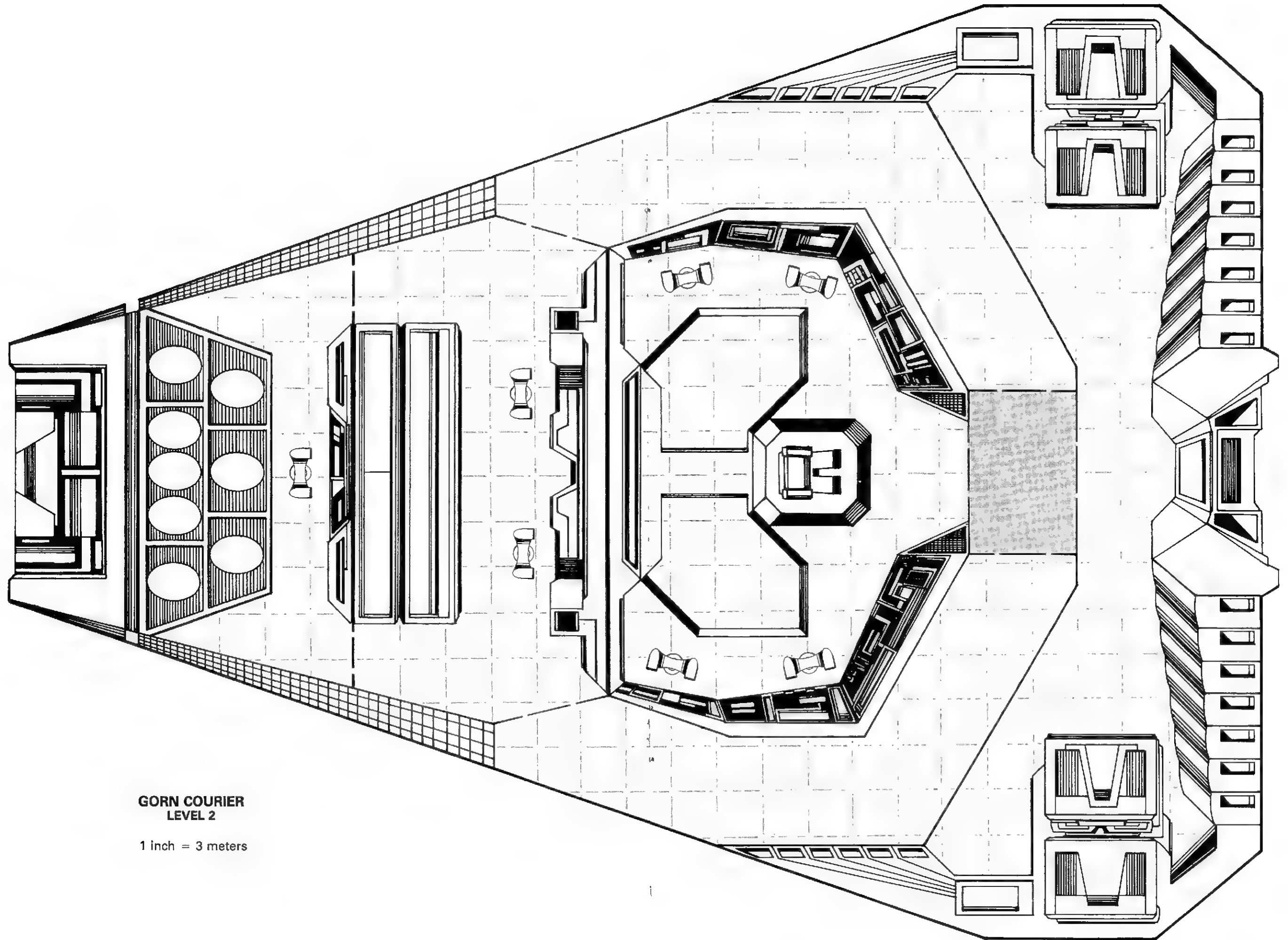

**GORN COURIER  
LEVEL 2**

1 inch = 3 meters



# Sensors Panel

## Sensors

DMGD  
2

DMGD  
1

OPER

1

2

3

4

5

6

7

8

9

10

### DETAILED DAMAGE CHART A ENGINES FORWARD

DIE ROLL	FORWARD PORT SHIELD Shield 1
1	Shield Generator Damaged
2	Beam Weapon Damaged (05)
3	Port Warp Engine
4	Port Warp Engine
5	Port Warp Engine
6	Port Warp Engine
7	Superstructure (1)
8	Superstructure (2)
9	Sensors Damaged
10	Bridge Hit

DIE ROLL	FORWARD SHIELD Shield 2
1	Shield Generator Damaged (05)
2	Beam Weapon Damaged
3	Missile Weapon Damaged (05)
4	Port Warp Engine
5	Starboard Warp Engine
6	Superstructure (1)
7	Superstructure (2)
8	Sensors Damaged
9	Bridge Hit
10	Bridge Hit

DIE ROLL	FORWARD STARBOARD SHIELD Shield 3
1	Shield Generator Damaged
2	Beam Weapon Damaged (05)
3	Starboard Warp Engine
4	Starboard Warp Engine
5	Starboard Warp Engine
6	Starboard Warp Engine
7	Superstructure (1)
8	Superstructure (2)
9	Sensors Damaged
10	Bridge Hit

DIE ROLL	AFT PORT SHIELD Shield 6
1	Shield Generator Damaged
2	Beam Weapon Damaged
3	Port Warp Engine
4	Impulse Engine (02)
5	Superstructure (02)
6	Superstructure (1)
7	Superstructure (1)
8	Superstructure (2)
9	Superstructure (2)
10	Superstructure (5)

DIE ROLL	AFT SHIELD Shield 5
1	Shield Generator Damaged
2	Missile Weapon Damaged (05)
3	Port Warp Engine
4	Starboard Warp Engine
5	Impulse Engine
6	Superstructure (1)
7	Superstructure (2)
8	Superstructure (3)
9	Tractor Beam Damaged
10	Engineering Out

DIE ROLL	AFT STARBOARD SHIELD Shield 4
1	Shield Generator Damaged
2	Beam Weapon Damaged
3	Starboard Warp Engine
4	Impulse Engine (02)
5	Superstructure (02)
6	Superstructure (1)
7	Superstructure (1)
8	Superstructure (2)
9	Superstructure (2)
10	Superstructure (5)

### DETAILED DAMAGE CHART B ENGINES AMIDSHIPS

DIE ROLL	FORWARD PORT SHIELD Shield 1
1	Shield Generator Damaged
2	Beam Weapon Damaged (05)
3	Port Warp Engine
4	Port Warp Engine
5	Port Warp Engine
6	Superstructure (02)
7	Superstructure (1)
8	Superstructure (2)
9	Sensors Damaged
10	Bridge Hit

DIE ROLL	FORWARD SHIELD Shield 2
1	Shield Generator Damaged
2	Beam Weapon Damaged
3	Missile Weapon Damaged (05)
4	Superstructure (1)
5	Superstructure (1)
6	Superstructure (2)
7	Superstructure (2)
8	Sensors Damaged
9	Bridge Hit
10	Bridge Hit

DIE ROLL	FORWARD STARBOARD SHIELD Shield 3
1	Shield Generator Damaged
2	Beam Weapon Damaged (05)
3	Starboard Warp Engine
4	Starboard Warp Engine
5	Starboard Warp Engine
6	Superstructure (02)
7	Superstructure (1)
8	Superstructure (2)
9	Sensors Damaged
10	Bridge Hit

DIE ROLL	AFT PORT SHIELD Shield 6
1	Shield Generator Damaged
2	Beam Weapon Damaged
3	Port Warp Engine
4	Port Warp Engine
5	Port Warp Engine
6	Impulse Engine (02)
7	Superstructure (1)
8	Superstructure (2)
9	Superstructure (2)
10	Superstructure (5)

DIE ROLL	AFT SHIELD Shield 5
1	Shield Generator Damaged
2	Missile Weapon Damaged (05)
3	Starboard Warp Engine
4	Port Warp Engine
5	Impulse Engine
6	Superstructure (1)
7	Superstructure (1)
8	Superstructure (3)
9	Tractor Beam Damaged
10	Engineering Out

DIE ROLL	AFT STARBOARD SHIELD Shield 4
1	Shield Generator Damaged
2	Beam Weapon Damaged
3	Starboard Warp Engine
4	Starboard Warp Engine
5	Starboard Warp Engine
6	Impulse Engine (02)
7	Superstructure (1)
8	Superstructure (2)
9	Superstructure (2)
10	Superstructure (5)

### DETAILED DAMAGE CHART C ENGINES AFT

DIE ROLL	FORWARD PORT SHIELD Shield 1
1	Shield Generator Damaged
2	Beam Weapon Damaged
3	Port Warp Engine
4	Superstructure (02)
5	Superstructure (1)
6	Superstructure (2)
7	Superstructure (2)
8	Superstructure (5)
9	Sensors Damaged
10	Bridge Hit

DIE ROLL	FORWARD SHIELD Shield 2
1	Shield Generator Damaged (05)
2	Beam Weapon Damaged
3	Missile Weapon Damaged (05)
4	Superstructure (1)
5	Superstructure (2)
6	Superstructure (2)
7	Superstructure (3)
8	Sensors Damaged
9	Bridge Hit
10	Bridge Hit

DIE ROLL	FORWARD STARBOARD SHIELD Shield 3
1	Shield Generator Damaged
2	Beam Weapon Damaged
3	Starboard Warp Engine
4	Superstructure (02)
5	Superstructure (1)
6	Superstructure (2)
7	Superstructure (2)
8	Superstructure (5)
9	Sensors Damaged
10	Bridge Hit

DIE ROLL	AFT PORT SHIELD Shield 6
1	Shield Generator Damaged
2	Beam Weapon Damaged (05)
3	Port Warp Engine
4	Port Warp Engine
5	Port Warp Engine
6	Impulse Engine (02)
7	Port Warp Engine
8	Superstructure (1)
9	Superstructure (1)
10	Superstructure (2)

DIE ROLL	AFT SHIELD Shield 5
1	Shield Generator Damaged
2	Missile Weapon Damaged (05)
3	Starboard Warp Engine
4	Starboard Warp Engine
5	Port Warp Engine
6	Port Warp Engine
7	Impulse Engine
8	Superstructure (1)
9	Tractor Beam Damaged
10	Engineering Out

DIE ROLL	AFT STARBOARD SHIELD Shield 4
1	Shield Generator Damaged
2	Beam Weapon Damaged (05)
3	Starboard Warp Engine
4	Starboard Warp Engine
5	Starboard Warp Engine
6	Impulse Engine
7	Starboard Warp Engine
8	Superstructure (1)
9	Superstructure (1)
10	Superstructure (2)

**Shield Generator Damaged** - Out for remainder of combat. 1 point of superstructure damage.  
**Weapon Damaged** - Out for remainder of combat. 1 point of superstructure damage.  
**Warp Engine** - Damage removed from Engine Power Track and Power Units Available Track.  
**Impulse Engine** - Damage removed from Engine Power Track and Power Units Available Track.  
**Superstructure** - Damage removed from Superstructure Damage Track.  
**Sensors Damaged** - Roll 1 die, 1-5 out for 1 game turn, 6-10 out for 2 game turns. 1 point of superstructure damage.  
**Tractor Beam Damaged** - Out for remainder of combat. 1 point of superstructure damage.  
**Bridge Hit** - Roll 2 dice for every 5 damage points or portion thereof. Consult table for effects. Skill and DEX rolls required.  
**Engineering Out** - No power to any other system. Skill Roll required to regain power.  
**Casualties** - Multiply number in parentheses by damage points in that shot to give % casualties.

# Helm Panel

Movement Point Ratio 2 / 1

Movement Points Available

Current  
Warp Speed

Engine Stress M  
Superstructure Stress K

Sub Light

W1

W2

W3

W4

W5

W6

W7

W8

W9

W10

Maximum Safe Cruising  
Speed: Warp 7

Emergency Speed:  
Warp 9

Movement Phases 1 2 3 4 5

0	1	2	3	4	5
			1		
2		1		1	
3	1		1		1
4	1	1		1	1
5	1	1	1	1	1
6	1	1	2	1	1
7	1	2	1	2	1
8	2	1	2	1	2
9	2	2	1	2	2
10	2	2	2	2	2
11	2	2	3	2	2
12	2	3	2	3	2
13	3	2	3	2	3
14	3	3	2	3	3
15	3	3	3	3	3
16	3	3	4	3	3
17	3	4	3	4	3
18	4	3	4	3	4
19	4	4	3	4	4
20	4	4	4	4	4

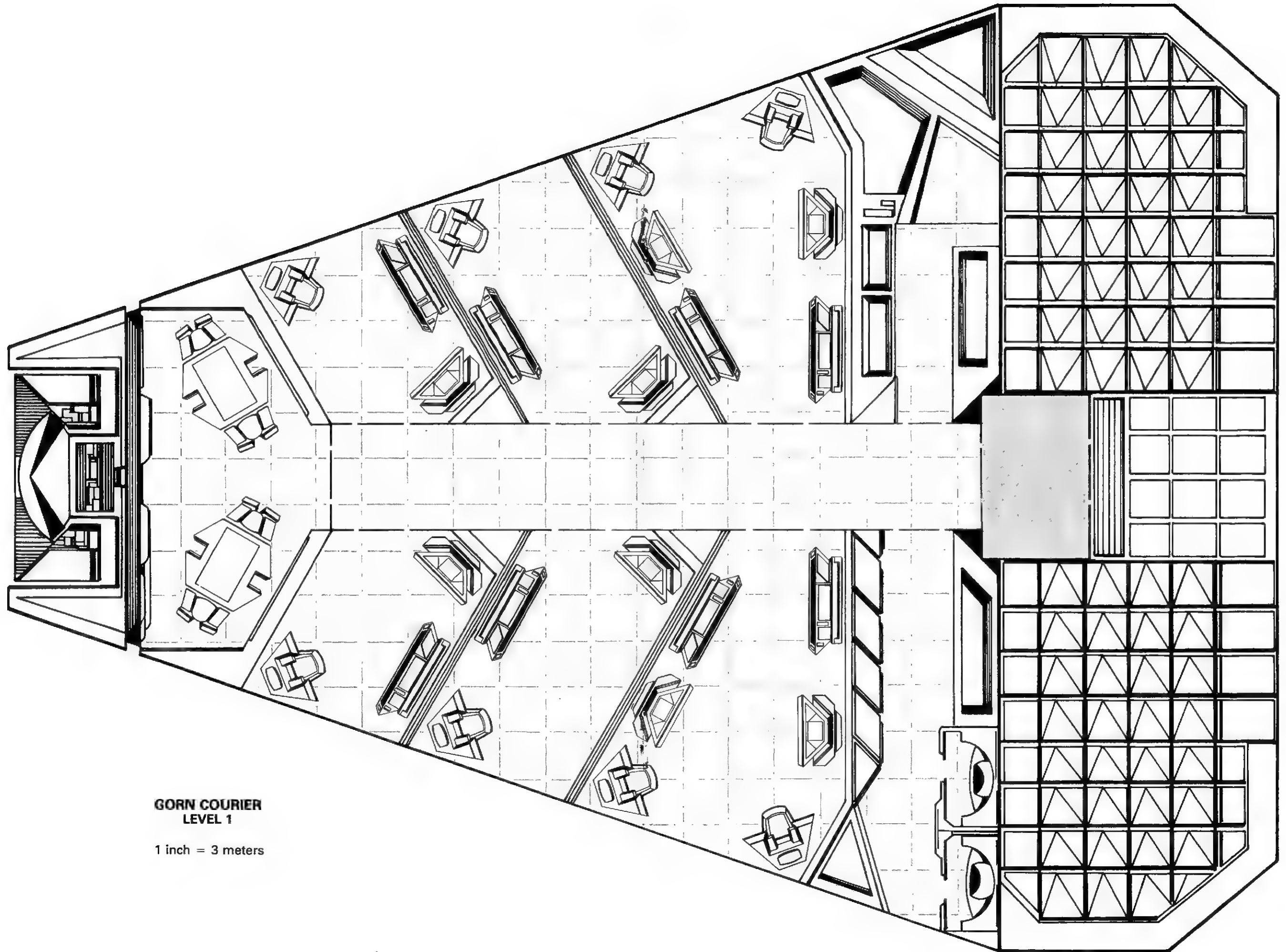

**GORN COURIER  
LEVEL 1**

1 inch = 3 meters

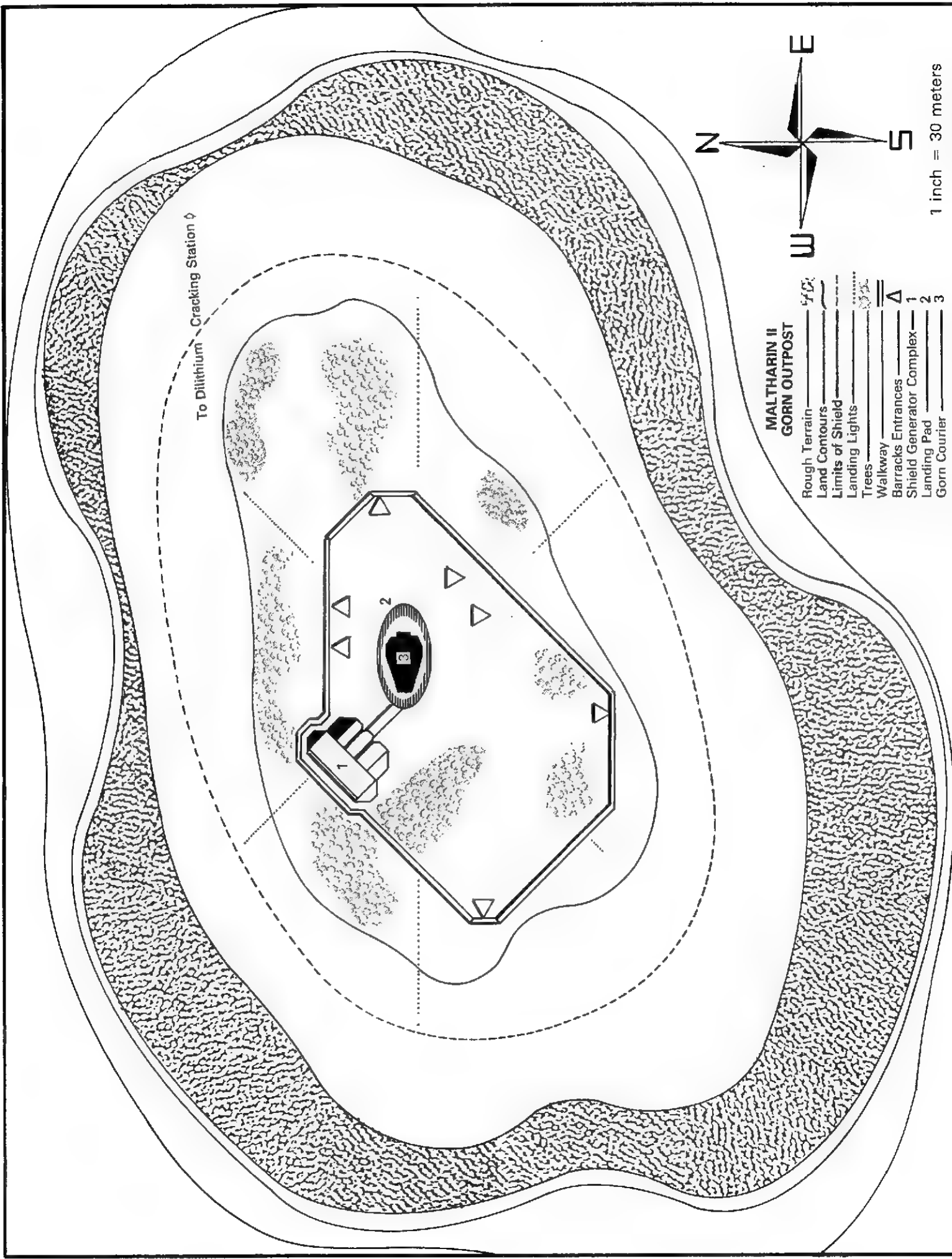

To Dilithium Cracking Station ↗

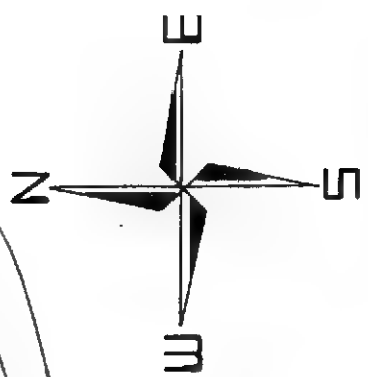

1 inch = 30 meters

**MALTHARIN II  
GORM OUTPOST**

- Rough Terrain ———— [stippled pattern]
- Land Contours ———— [wavy line]
- Limits of Shield ———— [dashed line]
- Landing Lights ———— [short horizontal dashes]
- Trees ———— [cluster of small circles]
- Walkway ———— [double line]
- Barracks Entrances ———— [triangle symbol]
- Shield Generator Complex ———— [numbered 1, 2, 3]
- Landing Pad ———— [numbered 1, 2, 3]
- Gorm Courier ———— [numbered 1, 2, 3]



## CS-6 CLASS COURIER

Gorn Alliance

### Hull Data:

Class — Gorn CS-6 Class Courier  
 Length Overall — 35 m  
 Width Overall — 26 m  
 Height Overall — 10 m  
 Weight — 5000 Tons  
 Crew — 8

### Engines And Power Data:

Total Power Units Available — 10  
 Movement Point Ratio — 1:1  
 Warp Engine Type — GWA  
 Number — 1  
 Power Units Available — 8  
 Stress Charts — Q/R  
 Maximum Safe Cruising Speed — Warp 5  
 Emergency Speed — Warp 6  
 Impulse Engine Type — GIA  
 Power Units Available — 2

### Weapons And Firing Data:

Beam Weapon Type — GBL-3 Blaster  
 Number — 1  
 Firing Arcs — fwd  
 Firing Chart — K  
 Power Range — 0-3  
 Damage Modifiers —  
 + 3(1-5) + 2(6-10) + 1(11-15)

### Shields And Damage Control Data:

Superstructure Points — 4  
 Superstructure Damage Chart — C  
 Deflector Shield Type — GSA  
 Shield Point Ratio — 2:1  
 Maximum Shield Power — 7

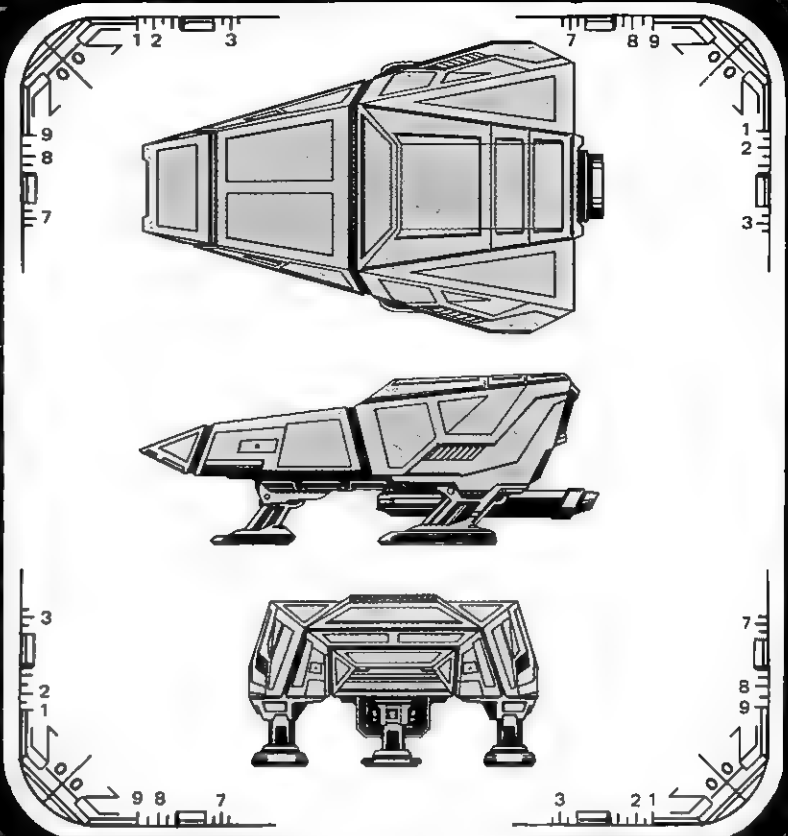

## MA-12 CLASS CRUISER

Gorn Alliance

### Hull Data:

Length Overall — 115 m  
 Width Overall — 81 m  
 Height Overall — 40 m  
 Weight — 50,000 Tons  
 Crew — 120

### Engines And Power Data:

Total Power Units Available — 40  
 Movement Point Ratio — 5:1  
 Warp Engine Type — GWC  
 Number — 2  
 Power Units Available — 18  
 Stress Charts — M/P  
 Maximum Safe Cruising Speed — Warp 6  
 Emergency Speed — Warp 8  
 Impulse Engine Type — GIC  
 Power Units Available — 4

### Weapons And Firing Data:

Beam Weapon Type — GBL-3 Blaster  
 Number — 4  
 Firing Arcs — 2 fwd port, 2 fwd stbd  
 Firing Chart — K  
 Power Range — 0-3  
 Damage Modifiers —  
 + 3(1-5) + 2(6-10) + 1(11-15)

### Shields And Damage Control Data:

Superstructure Points — 9  
 Superstructure Damage Chart — C  
 Deflector Shield Type — GSF  
 Shield Point Ratio — 2:1  
 Maximum Shield Power — 10

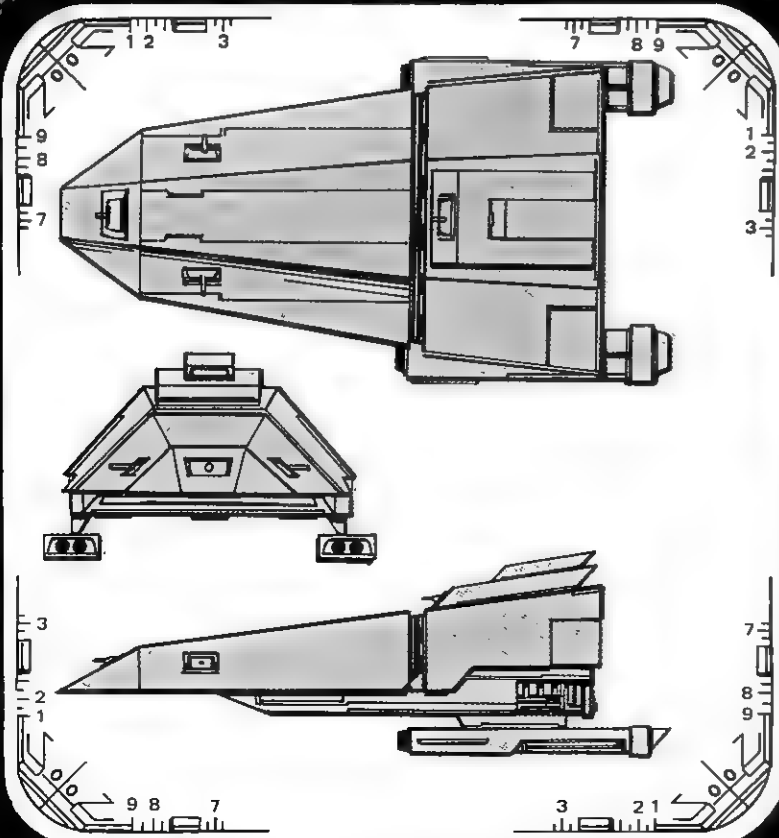

**Hull Data:**

Length Overall — 269 m  
 Width Overall — 134 m  
 Height Overall — 62 m  
 Weight — 95,000 Tons  
 Crew — 195



**Engines And Power Data:**

Total Power Units Available — 22  
 Movement Point Ratio — 2/1  
 Warp Engine Type — FWC  
 Number — 1  
 Power Units Available — 20  
 Stress Charts — M-K  
 Maximum Safe Cruising Speed — Warp 7  
 Emergency Speed — Warp 9  
 Impulse Engine Type — FIB  
 Power Units Available — 2

**Weapons And Firing Data:**

**Beam Weapon Type — FH — 4 Phasers**  
 Number — 6, mounted in 3 banks of 2  
 Firing Arcs — 2 fwd-port, 2 fwd, 2 fwd-stbd  
 Firing Chart — Q  
 Power Range — 0-3  
 Damage Modifiers —  
 + 2(1 - 8) + 1(9 - 14)  
**Missile Weapon Type — FP — 2 Photon Torpedoes**  
 Number — 2  
 Firing Arcs — fwd  
 Firing Chart — H  
 Power To Arm — 1  
 Damage — 6

**Shields And Damage Control Data:**

Superstructure Points — 10  
 Superstructure Damage Chart — C  
 Deflector Shield Type — FSC  
 Shield Point Ratio — 1:1  
 Maximum Shield Power — 8

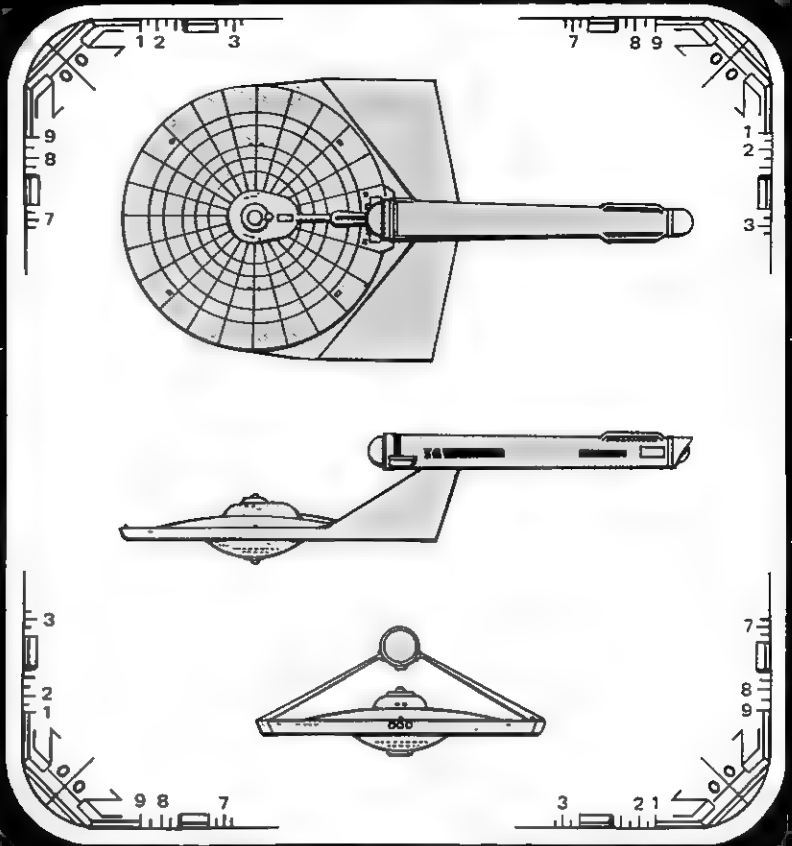

# WORLD LOG



System Name Maltharin  
 Number of Class M Present (D100 Roll) Single

D100 Roll for Number of Class M Present  
 01-90 = 1 Class M World  
 91 - 97 = 2 Class M Worlds  
 98 - 00 = 3 Class M Worlds

World Name Maltharin  
 Position in System (D10 Roll) IV  
 Number of Satellites (D10 Roll) 1  
 Planetary Gravity ( $\frac{1D10+5}{10}$ ) 1.1 G

D10 Roll for Number of Satellites  
 1-2 = 0 Satellites 9 = Satellites  
 4-6 = 1 Satellites 10 = Satellites  
 7-8 = 2 Satellites

**Planetary Size:**

Diameter 14,300 km  
 Equatorial Circumference 44,000 km  
 Total Surface Area 561,000,000 km<sup>2</sup>  
 Percent Land Mass (D100 Roll) 51 %  
 Total Land Area 286,110,000 km<sup>2</sup>

Diameter = 13,000km x Planetary Gravity  
 Circumference = 40,000km x Planetary Gravity  
 Total Surface Area = 510,000,000 x Planetary Gravity  
 Total Land Area = Total Surface Area x % Land Mass

**Planetary Conditions:**

Length of Day (14+2D10) 18 hours  
 Atmospheric Density (D10 Roll) Thick

D10 Roll for Atmospheric Density  
 1-2 = Thin Atmosphere  
 3-8 = Terrestrial Atmosphere  
 9-10 = Thick Atmosphere

General Climate (D100 Roll) Desert

D100 Roll  
 01-15 = Desert Climate 61-85 = Cool Temperate Climate  
 16-35 = Tropical Climate 86-00 = Arctic Climate  
 36-60 = Warm Temperate Climate

**Mineral Content (D100 Roll):**

Normal Metals 43% Radioactives 1% Industrial Crystals 18%  
 Special Metals Trace Gemstones 20%

# VESSELS

## LARSON CLASS DESTROYER

### HULL NUMBERS AND NAMES

The hull series 4300-4499 has been assigned to the Larson Class destroyers in Star Fleet service. Of the projected 199 ships of the class thus allowed for, 164 have been built, 38 lost in service or unaccounted for, and 17 scrapped or disarmed and sold to corporations or private research groups following the implementation of the Organian Peace Treaty and the military fleet reductions which followed.

Two ships, *Thermopylae* (NCC-4351) and *Alexander* (NCC-4449) have been withdrawn from service and drydocked for extensive upgrading and refitting, comparable to plans for the upgrading of the *Constitution*-class scheduled for initiation as ships complete their current 5-year assignments

Ships of this class are named for famous military leaders and battles of Terran history. Some examples include:

*Larson* (NCC-4300), class. Named for Admiral William Larson, hero of the Romulan Wars and victor at the battle of Gamma Hydra.

*Rommel* (NCC-4410) Named for Field Marshal Erwin Rommel, 20th-century European general.

*Leyte* (NCC-4319) Named for Battle of Leyte Gulf, a 20th-century naval engagement.

*Thermopylae* (NCC-4351) Named for Battle of Thermopylae, land engagement fought in 5th century, B.C.

*Hastings* (NCC-4404) Named for Battle of Hastings, land engagement fought in 1066 A.D.

One ship, NCC-4305, was outfitted for use by an Andorian crew. Unlike the majority of the class, the *Theleneth* is named for the Andorian admiral who defeated the Klingons at Donovan's Star at the cost of his own flagship 16 years ago.

### DISPOSITIONS AND EMPLOYMENT

The Larson class vessels are versatile, sharing many design features with the *Nelson*-class scout and the *Constitution*-class heavy cruiser. All three vessel types were designed and built at the same time the same firm. Most Larson-class destroyers are employed by the Star Fleet Military Division, though several are in the service of the Exploration Division on star mapping and survey duty.

Destroyers on military duty frequently are employed individually, on patrol duty in frontier areas. In time of war or other military emergencies, Larson-class destroyers may be assigned as escorts to convoys and vital civilian shipping, or used as scouts by squadrons and small fleets. The destroyer is also an excellent combat vessel, as well armed though not as powerful as a heavy cruiser.

## GORN ALLIANCE SHIPS

### COURIER

The Gorn courier *Sess'lessar*, the 'derelict' ship sending the distress call, and the courier at the outpost are Alliance equivalents of the Federation's *Mission*-class courier, described in the adventure *In The Presence Of My Enemies*, printed in the first-edition rules set. Designed to carry small parties on diplomatic and courier missions, they are used primarily by the Gorn embassy at the Clanhaven Conference.

Compared to its Federation equivalent, the Gorn courier is cramped; it contains only two decks, rather than three,

though each deck is slightly larger. Space provided for crew quarters and lounge is limited in keeping with the spartan simplicity of Gorn life.

Deck plans and a ship data sheet are provided. The upper deck holds the bridge, transporter room, computer, engineering, weaponry, and impulse engine facilities. The lower deck contains crew quarters and cargo space. The courier is not designed to carry separate passengers: its officers double as negotiators, and crew members double as bodyguard and retinue.

A single guard is on duty inside the courier at the outpost. After it has been captured, the courier can provide a radio. It can also be used to stage an escape attempt, but the outpost shields must be down first. Shields will be lowered if *Hastings* has departed, thus giving escapees a chance to get clear.

The courier's blaster may be used against targets on the ground once it has taken off. After one shot, shields will go up (if they still can). Prior to that, use the surface damage table given in the main body of the rules.

Should the courier be stolen, pursuit by Gorn cruisers is a possibility. This is a very one-sided sort of battle, so LUC and a generous gamemaster will probably be the only way the vessel would survive. It might be interesting if the departing *Hastings* were alerted to the escape and turned about racing to save the courier from certain destruction. This whole plot line is fairly unlikely, but could be developed if the situation seemed to be going that way.

### CRUISERS

The *Master Control Panel* should be duplicated and used to handle each Gorn cruiser involved in combat. Because these ships will not be boarded by the players, they are not detailed beyond the ship data sheet.

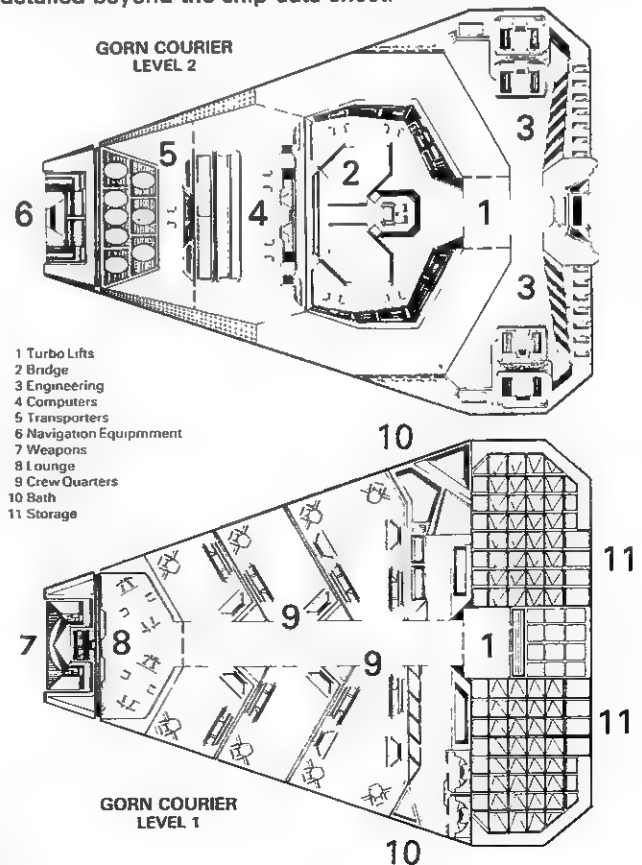



# BACKGROUND INFORMATION

## ARENA: THE FIRST CONTACT

The Federation outpost on Cestus III, in an unexplored stretch of frontier, was wiped out by a hitherto unknown star-faring race. A trap also was sprung against the *U.S.S. Enterprise*, using a faked message from Base Commander Travers to lure Captain Kirk into a prepared ambush.

The Federation officers escaped the trap and set out in pursuit of the ship which had brought the attackers. In the course of the pursuit, both ships were stopped by a powerful alien intelligence, the Metrons. Captain Kirk and the captain of the fleeing raider were set down on an artificial worldlet where they were to fight to the death. The outcome of the fight would settle the fate of the two ships.

The raider captain was a Gorn, a 2-meter-tall alien resembling a Terran reptile. In combat, the Gorn displayed great strength, endurance, and intelligence, but the human proved the more inventive, fabricating a crude gunpowder weapon from materials at hand. Kirk wounded the Gorn but mercifully refrained from killing him. The Metrons, who had secretly planned to destroy the winner of the battle as the greater threat to peace, spared both ships. Kirk gained insight into Gorn motivations during the fight, and recommended that the Federation negotiate with the Gorn Alliance to settle the border dispute that began the whole unfortunate incident.

## THE CLANHAVEN CONFERENCE

Progress on the peace conferences, now in their second year, has been slow, to say the least. Gorn culture is aggressive, expansionistic, and keyed to values quite unlike the basic roots of Federation philosophy and thought. Just understanding the Gorn (and getting them to understand the Federation) took quite some time. Problems in translating concepts and ideas have led to several near-breakdowns in the negotiating process.

Still, some solid gains have been made. The Frontier Accord of Stardate 8873.3 restricted buildups of military shipping within the disputed space between the two powers, with all armed vessels of greater than 100,000 tons kept out of the area entirely. A joint commission gradually has been drawing up an agreeable boundary.

There appears to be some resistance within the Gorn government to the decision to settle the dispute between the two powers by negotiation. Though the situation is far from clear, it seems that a political faction, a splinter group, or a military junta apparently has been pressing for the use of force to win concessions. A phrase translated as 'Manifest Destiny' has turned up in many Alliance statements and speeches. Evidently, the notion of a boundary holding back future Gorn expansion is not a popular one, and this has made final settlement of the treaty quite difficult.

Ambassador Shras of Andor, the current head of the Federation negotiating team, is the third Federation ambassador assigned to the Clanhaven talks. His latest reports indicate he is cautiously optimistic, but worried about the possibility of short-term problems. The next few months, experts say, will be crucial in determining the outcome of the conferences. Failure to settle matters diplomatically could lead to war. It would be a war easily won by superior Federation resources, but costly in lives, in money and material, and in the possible leverage other rivals like the Klingons and the Romulans might gain from Federation preoccupation with the Gorn situation.

## THE GORN ALLIANCE

The Gorn evolved originally on the planet S'garon, a class M, temperate world with a gravity of 1.4 G, a normal atmosphere, and a land percentage of 45%. A strong, hardy race, the Gorn developed a culture which, by and large, stressed the virtues of strength and courage, as well as the natural dominance of those who demonstrate their fitness to rule through those virtues.

*Ussegssirr*, most often translated as 'Manifest Destiny,' has long formed one of the basic tenants of Gorn philosophy. Since before the Gorn reached into space for the first time, it has been believed that the strong have both the right and the duty to extend their dominion over the weak. It has been considered wrong for the strong to be limited or denied.

*Ussegssirr*, balanced by *Gessegrissgir* and usually rendered as 'Honor,' is a complex code of behavior and thought understood by few non-Gorns. Basically, the weak are expected to serve the strong (in an almost feudal hierarchy of rising power beneath a single ruler), but the strong, in turn, are expected to adhere to the Warrior's Code of *Gessegrissgir*. Superiors must be obeyed, inferiors treated with justice, and a complicated pattern of obligations and responsibilities must be followed governing all aspects of Gorn life. As one Federation observer has said, "Gorn 'Honor' makes the *giri* and *gimu* of Old Japan look like something just short of sheer anarchy!"

The traditional patterns of 'Destiny' and 'Honor' served the Gorn well enough to see them unify their world and reach into space, but the social system was ill-equipped to survive the transitions brought about by the discovery of warp technology. Though the principle of *Ussegssirr* had been applied with increasing frequency to the Race as a whole, it came close to breaking down when problems of time and distance over interstellar space became clear.

The Gorn expanded rapidly, colonizing several new worlds and conquering at least four races who failed to prove themselves strong enough to resist. Individual colony worlds began to struggle for precedence in the Gorn social order in the time-honored fashion, however, and there was soon a civil war threatening to shatter the entire Gorn empire.

A particularly powerful colony eventually won sufficient dominance to rival S'garon itself, leading to a massive confrontation. This dangerous state of affairs was resolved by Graaka, the Autarch of the Race. Realizing that continued, constant strife as demanded by old interpretations of *Ussegssirr* and *Gessegrissgir* conflicted with the higher destiny of the Gorn race, Graaka chose the new over the old and sought a massive reform. He successfully defeated the rival fleet, and then did something no Gorn had ever done before: he offered the vanquished a share of the government.

As important to the Gorn as the Vulcan philosopher Sarak was to his people at an earlier time, Graaka established a new society. Rather than struggling among themselves for dominance, the Gorn directed their aggression outward, against the rest of the Galaxy. To preserve their strength for the real fight for dominance among lesser races, they abandoned infighting as a form of governmental selection. Through negotiation and diplomacy, arts rarely practiced by the Gorn prior to this time, Graaka persuaded the various Gorn worlds to look upon themselves as independent but equal. A council was formed from among all the worlds in Gorn space. Graaka's new government became known as the Gorn Alliance.

At the head of the Alliance were the Dual Autarchs. One Autarch continued to be the most powerful leader on S'sgaron, the Gorn home world and the strongest individual world of the Alliance; the other was selected from the colonies, a concession so that the colonies could see they really did have an equal voice. The colonial Autarch was selected according to Council precedence; the world leader chosen shifted as the patterns of precedence changed.

This was not, as some preliminary Federation reports indicated, a sudden blossoming of democracy. The 'voice of the people' meant nothing in the Alliance; council decisions were arrived at through voting, but votes shifted according to the proven strength of the various factions. In the new Alliance, however, open military confrontation usually was no longer the key to proving a faction's strength. Rather, factions waxed and waned with success, failure, and the subtle dictates of *Gessegrissgir*.

It was a clumsy arrangement, with the dual Autarchs a particularly weak link in the chain. The Autarch from S'sgaron tended to be conservative, cautious, and traditional; the colonial Autarch usually commanded the council's 'actionist' faction. Failure to agree on many basic issues led to protracted council battles. In the end, this gave free rein to the actionists, who advocated 'nothing ventured, nothing gained.' Since the ultimate test of the validity of any position was success or failure, the actionists usually forced action upon the Gorn. When the action worked, the actionists were vindicated. When it failed, it frequently was too late to back out.

A case in point is the chain of events leading up to the Gorn raid on Cestus III. The Gorns became aware of the Federation before the Federation had any inkling of Gorn existence. Outposts and colonies were being planted in an area seen as being Gorn space. This was intolerable under *Ussegssirr*, Gorn racial 'Destiny.'

Though the conservatives agreed that the Federation was trespassing on Gorn space, they argued that a trial of strength wasn't necessary yet and no immediate action need be taken. The actionists were of a different mind; they wished to strike quickly, to establish their superiority over the interlopers and to force the Federation to submit. The raid on Cestus III was ordered by the colonial Autarch, an actionist, when an impasse was reached in council.

Although the base on Cestus III was destroyed, it became obvious during the course of the raid that a drastic mistake had been made. The Gorn cruiser making the raid, commanded by the colonial Autarch's most able son, clashed with a superior vessel, the Federation starship *Enterprise*, and was forced to beat a hasty retreat. The *Enterprise* pursued, and the Metrons intervened.

The Gorn captain relished the contest, for it was perfectly in line with his traditional values. He proved stronger, tougher, even more cunning in several instances. In the end, he was beaten, but the human failed to exploit the victory. Kirk, in fact, risked death as well as the destruction of the *Enterprise* by showing mercy to the defeated Gorn leader and sparing his life. Furthermore, Kirk spoke of settling the border question through diplomacy and negotiation, though the Federation had proven itself superior in battle both collectively and individually.

All this had a profound impact on the Gorn captain. When he returned to the Alliance, he became a strong advocate of solving the border question peaceably, a position held by the conservatives. The actionists held that the Federation was demonstrating weakness, that the success was won by the *Enterprise* was a fluke. They contended that war was still the only answer and that anything else was to invite the Federation to subjugate the Race as the Race would certainly have done to the Federation. This, they said, was not to be tolerated. The actionists had failed once already, and that

failure took its toll. The faction fragmented into many smaller parties, and Gorn society is now near the breaking point.

The slow progress of the peace conference can thus be seen to stem from several major roots. Pride and tradition make the Gorn reluctant to treat any other race as equals. They show a certain grudging respect for the fighting prowess of a strong opponent (The greater the foe, the greater the glory seems to be the working principle here.), but they have been taught that the Race and its 'Destiny' are paramount. Thus it is hard for them to admit that another race could be equal — or superior.

A second factor is fear. Tradition says that the Gorn have proven weaker than the Federation. They expect the Federation to exploit this as they would if the situation were reversed. That this could mean the end of the Gorn way of life is a prospect to frighten even the most stalwart warrior.

Finally, the Gorn find Federation culture incomprehensible. An equal relationship not subject to the bonds of *Gessegrissgir* is simply beyond their understanding. Thus, distrust and mutual suspicion have been heightened throughout the negotiations by this failure to reach a basic understanding across cultural barriers. An example is the early difficulties that arose when the Gorn Ambassador remarked to the Andorian Chargé d'Affaires, "We have trouble dealing with a race with no concept of the Warrior's Code of behavior (*Gessegrissgir*)." Computers unable to fully understand the cultural basis of Gorn society translated this statement as "We have trouble dealing with a race that has no concept of honor." The reaction by the Andorian diplomat was predictable and quite unfortunate, but luckily no permanent damage was done by the mistranslation and its aftermath.

Even now, *Gessegrissgir* and the complex net of obligation and responsibility can be approached only in the most vague and general ways. It is nothing like the more simple, straightforward honor code of the Romulans, for the Romulans do not have the complex formalism of Gorn culture.

Many, if not most, Gorn actions and attitudes are shaped and impelled by their code. Various imperatives, known as 'Demands of Honor,' are dictated by the code. Failure to obey and accomplish these imperatives makes it impossible for the Gorn to uphold his prestige and position in society.

Federation ambassadors still do not fully understand the "Demand of Honor," but it is well-realized that failure to admit a Gorn's 'Demand of Honor' is to risk a confrontation. In the current diplomatic situation, Federation policy is to tread warily, granting such 'Demands of Honor' that do not directly compromise Federation security, and seeking a mutually satisfactory alternative when security may be involved.

## MALTHARIN II

Maltharin II is the single class M planet of the Maltharin system, an obscure and uninhabited system not far from the Federation-Gorn frontier. The world is one of several planets still subject to Federation and Alliance dispute. Though it lies well within the Federation sphere of influence, only 3 parsecs from Veldenia V, the Gorn discovered and surveyed the world first. After discovering a concentration of dilithium crystals there, they established an outpost and a dilithium cracking station. The Gorn have evacuated the outpost pending settlement of the dispute, but the dilithium wealth of the world makes Maltharin II a major bone of contention.

The outpost is typical of those set up by the Gorn Alliance on worlds of strategic or economic importance within their territory. There is a military landing field, barracks, a shield generator station, and various underground service, storage, and administrative structures to support a garrison of up to 300 troops. The cracking station employed 50 technicians and workers.

# CAST OF CHARACTERS

## CREW OF THE USS HASTINGS

Several of the characters here, particularly the senior officers and department heads, have been generated in detail. They are suitable for use as player characters. A few others have less detailed treatments; these may serve as extra characters or substitutes in the absence of player characters.

### SENIOR OFFICERS AND DEPARTMENT HEADS

Players may use the detailed characters to play the adventure with, or they may replace any character with a player character that they have created themselves. If there are not enough players to fill all the senior positions (Captain, First Officer, Chief Medical Officer, Chief Engineer, and Security Chief), the unfilled positions will be filled by the detailed characters as NPCs. Lt. Travers may not be replaced.

### SECONDARY OFFICERS

Characters provided are suitable as NPCs or secondary characters for use by players in situations, such as starship combat, where some crucial player characters are absent and must be replaced by a substitute. These NPCs could be used either aboard ship or in boarding/landing parties, as desired; players whose primary characters are not participat-

ing in the current main thrust of action can run the NPC characters to keep busy during such lulls, and to relieve the gamemaster of the task. They can be expanded somewhat into player characters or more detailed NPCs, if the Gamemaster desires. Think of these characters as equivalent to the semi-regulars of the *STAR TREK* TV series — Riley, Kyle, DeSalle, and others.

### INCIDENTAL OFFICERS AND CREWMEN

These characters are included to fill specific functions, or to provide a pool from which a landing party or boarding party can be drawn. As such, they are not detailed greatly.

Additional characters may be freely created, of course, as additions and/or substitutions for the individuals presented here. These characters allow the Gamemaster to introduce needed personnel quickly, without having to pause to roll them up.

### THE PASSENGERS

All characters presented here should be treated strictly as NPCs controlled by the gamemaster. A player might handle dice rolls for one of the Gorn, if the character were assisting in a space combat or similar situation.

Gorn characters are fleshed out somewhat from the basic Gorn NPC outlines given in the basic rules, but they follow no hard-and-fast character generation system. (Sufficient interest in Gorn characters might eventually prompt release of a complete Gorn background and character creation book, in the tradition of *The Klingons*, already available from FASA.)

Name: STUART, Charles E.

Rank: Commander

Current Assignment: Military Operations Command,  
USS *Hastings*, NCC-4405

Position: Captain

Race: Human

Sex: Male

Age: 33

STR — 65

END — 61

INT — 80

DEX — 72

To-Hit, Modern: 52

H-T-H: 52

Bare-Hand Damage: 1D10+4

CHA — 73

LUC — 89

PSI — 22

UNC SAVE LVL — 30

UNC THRESH — 6

AP — 11

### Important Skills

Skill	Rating
Computer Operation	60
Language (Andorian)	10
Leadership	84
Negotiation/Diplomacy	75
Shuttlecraft Pilot	37
Starship Combat Strategy/Tactics	90
Starship Helm Operation	58

### Distinguishing Physical Characteristics:

Stuart is stocky, but fit and handsome. He wears his sandy brown hair rather short.

### Brief Personal History:

Cadet Cruise, USS *Lexington*, High Honors.

USS *Enterprise*, 2 years.

Captain Stuart has been called "one of the most promising commanders in Star Fleet." It is likely that he will be selected for command of a *Constitution* class ship when he eventually attains the full rank of Captain. He has served in the Military Operations Command for the past 4 years, and as a Commander for three years, the last two in command of the *Hastings*.

### Personality

#### Motivations/Desires/Goals:

His most serious flaw is his ambition, which leads him to take risks and attempt actions that are sometimes foolish, often dangerous, and always challenging — all in the hope of achieving recognition and promotion.

#### Manner:

Stuart is a competent commander, decisive and resilient. He gets on well with his crew, finding in First Officer Thonen a kindred spirit, in Dr. Tremaine a friend, and in most of the other officers and men a band of comrades to whom he gives the same sort of loyalty he receives.

### Special Knowledge/Powers:

None.

**Name: THONEN, K'ras**

**Rank:** Lt. Commander  
**Current Assignment:** Military Operations Command,  
*USS Hastings, NCC-4405*

*Position:* First Officer

**Race:** Andorian  
**Sex:** Male  
**Age:** 33

STR — 79                      CHA — 62  
END — 60                      LUC — 67  
INT — 85                      PSI — 38  
DEX — 56

To-Hit, Modern: 62  
H-T-H: 63

Bare-Hand Damage: 2D10+2 AP — 9

**Important Skills**

<i>Skill</i>	<i>Rating</i>
Computer Operation	65
Electronics Technology	10
Language (Andorian)	40
(English)	40
(Caitian)	10
Leadership	61
Negotiations/Diplomacy	33
Starship Combat Strategy/Tactics	77
Starship Sensors	56

**Distinguishing Physical Characteristics:**

The First Officer often appears rather clumsy and awkward, but this is due to environmental differences between his homeworld and the ship's terrestrial environment. Like many of his race, he is left-handed.

**Brief Personal History:**

Cadet Cruise, *USS Excalibur*, Honors.  
Galaxy Exploration Command, *USS Yorktown*, 3 years.  
Galaxy Exploration Command, *USS Republic*, 5 years.

Thonen is an Andorian, fiercely proud of his warrior heritage. He has had a consistently excellent record, serving his entire career in Star Fleet in the coveted *Constitution*-class starship berths, rising to the post of Chief Navigator aboard the *Republic* before being promoted to his new assignment.

**Personality**

**Motivations/Desires/Goals:**

Thonen is ambitious; his secret hope is to become the first Andorian to receive a *Constitution*-class command. Unfortunately, it is not a dream he is likely to realize, for Thonen makes a far better First Officer than he will a Captain, unless he learns a sense of moderation and balance.

**Manner:**

Thonen's primary talents are military; an excellent tactician and fighter, he is lacking in comparable skills of peace so essential to command rank. Thonen is a brisk and efficient officer, a fine second-in-command, but his judgement is apt to err in the direction of over-aggressiveness. This is in some ways unfortunate, because the Captain himself tends that way, and thus the First Officer cannot serve as a check or balance to the Captain's personality.

**Special Knowledge/Powers:**

None.

**Name: ARMAND, Marie**

**Rank:** Lieutenant  
**Current Assignment:** Military Operations Command,  
*USS Hastings — NCC-4405*

*Position:* Science Officer

**Race:** Human  
**Sex:** Female  
**Age:** 33

STR — 53                      CHA — 74  
END — 62                      LUC — 95  
INT — 90                      PSI — 27  
DEX — 70

To-Hit, Modern: 61  
H-T-H: 48

Bare-Hand Damage: 1D10+3 AP — 11

**Important Skills**

<i>Skill</i>	<i>Rating</i>
Astronomy	50
Computer Operation	85
Language (English)	40
(French)	40
(Vulcan)	39
Physics	51
Planetary Ecology	45
Shuttlecraft Pilot	37
Starship Sensors	73

**Distinguishing Physical Characteristics:**

Lt. Armand could be a beautiful woman, but her emotionless expression and severe, functional hairstyle and dress make her seem more plain than she actually is.

**Brief Personal History:**

Cadet Cruise, Galaxy Exploration Command  
Galaxy Exploration Command, *USS Lexington*, 2 years.  
Galaxy Exploration Command, *USS Enterprise*, 5 years.

Science Officer Armand is an individual of special distinction; she learned much of her trade in a recent tour of duty as Assistant Science Officer aboard the *U.S.S. Enterprise*, under the tutelage of Commander Spock of Vulcan. She (and most others in Star Fleet) looks upon this as one of the greatest honors of her life.

The Lieutenant is a generalist in science, rather than a specialist; her highest duty skills, computer operation and starship sensors, indicate that she spends more time assembling and analyzing data than in pure research. This makes her the ideal Science Officer, especially for a ship like *Hastings*; in-depth knowledge on any particular subject is of far less value to her than a broad range of knowledge and the ability to apply it as needed.

**Personality**

**Motivations/Desires/Goals:**

Her service aboard *Enterprise* left Armand fascinated (no pun intended) by Vulcan culture and philosophy. She learned a fair amount of Vulcan from Spock (who termed her "an apt pupil;"). But though she has aspired to be as cool, rational, and cerebral as her mentor, the Lieutenant is emotional by nature. Her mask of almost-Vulcan logic tends to slip in moments of great personal and professional stress.

**Manner:**

Science Officer Armand is a dedicated professional, but far prefers exploration duty to the military aspects of Star Fleet. She (with Saalik) is a primary source of restraint and cool, clear-headed advice, serving to offset the more aggressive tendencies of Stuart and Thonen. She feels warmly toward Saalik, much as a sister toward an older brother.

She has rebuffed every advance Navigator Ortez (who sees himself as a lady-killer) has offered, to the point where it has become a familiar routine.

**Special Knowledge/Powers:**

Armand has been trained in some of the simpler Vulcan mind techniques, first by Commander Spock and now by Lieutenant Saalik.



**Name: SINCLAIR, Douglas Ian**

**Rank:** Lieutenant Commander  
**Current Assignment:** Military Operations Command,  
*USS Hastings* — NCC-4405

*Position:* Chief Engineer

**Race:** Human

**Sex:** Male

**Age:** 35

STR — 58                      CHA — 73  
END — 58                      LUC — 68  
INT — 90                        PSI — 31  
DEX — 73

To-Hit, Modern: 47

H-T-H: 57

Bare-Hand Damage: 1D10+4 AP — 11

**Important Skills**

<i>Skill</i>	<i>Rating</i>
Astronautics (Strsh. Engr.)	82
Computer Operation	55
Computer Technology	33
Damage Control Procedures	60
Deflector Shield Technology	10
Electronics Technology	40
Life Support Systems Technology	20
Mechanical Engineering	46
Personal Weapons Technology	10
Starship Weaponry Technology	10
Transporter Operations	48
Warp Drive Technology	72

**Distinguishing Physical Characteristics:**

The Chief Engineer's flaming red hair is something of a personal trademark, as is the assortment of random grease stains that usually smudge his face and hands.

**Brief Personal History:**

Sinclair is one of Star Fleet's many Scot Engineers. Variously described as 'a manic tinker' and 'the junkyard mechanic,' he has considerable talents in adapting equipment others consider old or worn-out into serviceable gear.

Off duty, Sinclair keeps himself busy with a small, highly illegal still concealed in one of the Engineering Supply compartments. Actually, the Captain is well aware of the source of the ship's home brew, but, being partial to the Engineer's liquor himself, manages to remain officially unaware of the entire situation.

**Personality**

*Motivations/Desires/Goals:*

Sinclair's main object in life is to have his ship earn an efficiency rating better than that of the *USS Enterprise*. An old rivalry with Engineer Montgomery Scott, who taught a course in Astronautics at the Academy and rode Midshipman Sinclair unmercifully in a desire to see the young officer develop his talents, has made Sinclair want to prove himself as a first-rate engineer.

*Manner:*

Though talented in his field, Sinclair has few social graces. Aboard the *Lexington*, he once attended a welcoming dinner for a distinguished Federation ambassador in grease stained coveralls because he had completely forgotten to change clothes when coming off duty!

**Special Knowledge/Powers:**

None.

**Name: SAALIK**

**Rank:** Lieutenant  
**Current Assignment:** Military Operations Command,  
*USS Hastings*, NCC-4405

*Position:* Chief Helmsman

**Race:** Vulcan

**Sex:** Male

**Age:** 39

STR — 93                      CHA — 74  
END — 89                      LUC — 20  
INT — 95                        PSI — 89  
DEX — 72

To-Hit, Modern: 46

H-T-H: 57

Bare-Hand Damage: 2D10+1 AP — 11

**Important Skills**

<i>Skill</i>	<i>Rating</i>
Astrogation (Starship Navigation)	57
Astronomy	37
Computer Operation	72
Damage Control Procedures	30
Electronics Technology	20
Language (Andorian)	10
(Vulcan)	40
Leadership	54
Negotiation/Diplomacy	33
Shuttlecraft Pilot	62
Starship Combat Strategy/Tactics	40
Starship Helm Operation	83
Starship Weaponry Operation	57
Starship Weaponry Technology	38

**Distinguishing Physical Characteristics:**

Tall and graceful, Saalik displays the typical Vulcan build.

**Brief Personal History:**

Cadet Cruise, Military Operations Command.

Star Base 12 Headquarters, 3 years.

Merchant Marine Command, 2 years.

Colonial Operations Command, 5 years.

Military Operations Command, 2 years.

Colonial Operations Command, 2 years.

Saalik has devoted his considerable talents to the job of Helmsman, and is a fine one indeed.

His closest friend, though the friendship is pretty much one-sided, is Science Officer Armand; he is continuing Commander Spock's instruction of the woman in Vulcan language and in some of the simpler Vulcan mental and emotional disciplines. Armand's feelings towards Saalik are those of a sister towards a respected older brother; the Vulcan's feelings, of course, are not a subject of display or discussion.

**Personality**

*Motivations/Desires/Goals:*

Saalik has some difficulties in dealing with his duties aboard *Hastings*. He is not good with people, particularly Humans. His Vulcan devotion to intellect, his high standards of perfection, and his inability to fit into the easy camaraderie of the wardroom and the crew make him a distant and rather cold figure, cut off from the others. He also finds the aggressive nature of Captain Stuart and First Officer Thonen difficult to understand, preferring as he does to weigh all risks and arrive at logical courses of action. The Vulcan helps counterbalance his two superiors somewhat.

*Manner:*

Saalik is typical of his race in many ways. He is logical, calculating, and capable of completely suppressing all emotions.

During stressful moments on the bridge, when Navigator Ortez is waxing oathful, Saalik frequently makes disdainful observations concerning the waste of energy and general inefficiency of Humans in general and Human navigators in particular. The relationship between Ortez and Saalik is not unlike the famous Spock-McCoy relationship; both disparage the attitudes and actions of the other, but their barbed comments mask a deep and genuine respect and loyalty to one another.

**Special Knowledge/Powers:**

Saalik is practiced in all Vulcan mind techniques and in the Vulcan nerve pinch. Totally ambidextrous, he can use his marksmanship and hand-to-hand fighting abilities equally well with either hand.

**Name: TREMAINE, Lisa Anne****Rank:** Lieutenant*Title:* M.D.**Current Assignment:** Military Operations Command,  
*USS Hastings, NCC-4405**Position:* Chief Medical Officer**Race:** Human**Sex:** Female**Age:** 37

STR — 55

CHA — 90

END — 56

LUC — 70

INT — 86

PSI — 39

DEX — 74

To-Hit, Modern: 52

H-T-H: 60

Bare-Hand Damage: 1D10+4 AP — 11

**Important Skills**

<i>Skill</i>	<i>Rating</i>
Art (Painting)	41
Computer Operation	61
Damage Control Procedures	30
General Medicine (Human)	70
(Andorian)	48
(Vulcan)	47
Language (English)	40
(French)	21
Life Support Systems Technology	10
Psychology (Human)	49
(Andorian)	22
(Vulcan)	14

**Distinguishing Physical Characteristics:**

Dr. Tremaine's long, blonde hair is her most striking characteristic, and it helps her look younger than she actually is.

**Brief Personal History:**

Cadet Cruise, Galaxy Exploration Command, Honors.

Military Operations Command, 2 years.

Galaxy Exploration Command, *USS Farragut*, 3 years.

The doctor is perhaps the most popular member of the wardroom; she is strikingly beautiful as well as extremely competent and intelligent. This is her first posting as senior medical officer on independent duty.

In her spare time, she likes to paint, particularly exotic landscapes of worlds visited by *Hastings*. She often finds excuses to join landing parties to take photographs and get the feel of new places, even when her services are unlikely to be necessary. A small gallery of her paintings decorates sick bay, and most of the officers have hung pictures of favorite ports of call in their cabins.

**Personality****Motivations/Desires/Goals:**

Tremaine went into space to escape an unhappy love affair on Terra, and thus she fears the strains of getting too deeply involved in another emotional relationship. She has discovered that she enjoys her new career and loves her work. These twin motivations, however, are at odds with an essentially romantic nature, which she expresses through her painting, for the most part.

**Manner:**

Dr. Tremaine does her best to remain detached from emotional involvements on board ship, but manages it in such a way as to avoid bruised egos or bad feelings.

Because this is her first department head posting, she is still unsure of herself at times. This is especially true when it comes to dealing with aliens like Thonen and Saalik; though she is reasonably competent, she frequently is concerned that something will happen to one of them that she is unable to patch up. With Humans, she is more confident, but the strain of making life-or-death decisions without backup does worry her at times.

**Special Knowledge/Powers:**

None.

**Name: WATANUBE, Hideki T.****Rank:** Lieutenant**Current Assignment:** Military Operations Command,  
*USS Hastings, NCC-4405**Position:* Chief Communications/Damage Control Officer**Race:** Human**Sex:** Male**Age:** 32

STR — 58

CHA — 68

END — 57

LUC — 62

INT — 77

PSI — 20

DEX — 70

To-Hit, Modern: 62

H-T-H: 50

Samurai Sword: 41

AP — 11

Bare-Hand Damage: 1D10+3

**Important Skills**

<i>Skill</i>	<i>Rating</i>
Communication Systems Operation	77
Communication Systems Technology	46
Computer Operation	75
Damage Control Procedures	60
Electronics Technology	41
Language (Andorian)	50
(English)	60
(Japanese)	40
(Vulcan)	35
Negotiation/Diplomacy	48
Samurai Traditions/Culture	30
Small Equipment Systems Technology	27
Starship Sensors	46

**Distinguishing Physical Characteristics:**

Watanube is slim and athletic; he has been known to shave his head, leaving a pigtail (queue) in traditional Samurai fashion. Having made his point to crewmates who wanted to joke about his Samurai interests, now he wears his hair in a short, utilitarian style.

**Brief Personal History:**

Cadet Cruise, Colonial Operations Command, Honors.

Colonial Operations Command, 2 years.

Galaxy Exploration Command, *USS Farragut*, 2 years.

Galaxy Exploration Command, *USS Exeter*, 3 years.

Watanube is the nephew of Admiral Tomoyuki Watanube, an important member of Star Fleet General Staff; his joining the service carries on a family tradition that goes back many generations. When he first arrived on board *Hastings*, there was considerable questions about whether or not he actually merited a senior officer's berth. His previous positions had been either with the Colonial Operations Command (not considered a particularly strenuous Star Fleet post), or with his father on the elder Watanube's two flagships, *Farragut* and *Exeter*, prior to his selection for a staff assignment. Young Hideki was looked upon as an example of Star Fleet favoritism, a rare but still occasional occurrence.

**Personality****Motivations/Desires/Goals:**

Watanube, though highly competent, has doubts about his abilities and spends a lot of time wondering if his career would have been as smooth if he were not an Admiral's nephew. He feels that he will not have many chances to prove his worth as a Communications specialist, and so he has applied for transfers to several other departments on board, though all his requests were turned down; the Captain has long since realized Watanube's worth in Communications.

**Manner:**

Because of his self-doubts, he has applied himself hard to his job, and is continually strives to prove himself. Open, friendly, and cheerful, Watanube has proven him worth to everyone on board many times over — except to the most important judge of all, himself. The young officer frequently volunteers for landing party duty.

**Special Knowledge/Powers:**

Of all the officers aboard the *Hastings*, Watanube perhaps will have the easiest time understanding the Gorn because of his deep interest in Samurai traditions. The codes of honor and conduct, though not the same or even very close, are close enough that he might be able to interpret the Gorn idea of 'Demand of Honor.'

**Name: ORTEZ, José Manuel**

**Rank:** Lieutenant, JG  
**Current Assignment:** Military Operations Command,  
*USS Hastings, NCC-4405*  
*Position:* Chief Navigator

**Race:** Human  
**Sex:** Male  
**Age:** 29

STR — 70                      CHA — 70  
 END — 71                     LUC — 86  
 INT — 82                     PSI — 24  
 DEX — 71  
 To-Hit, Modern: 58  
 H-T-H: 62  
 Bare-Hand Damage: 1D10+5    AP — 11

**Important Skills**

<i>Skill</i>	<i>Rating</i>
Astrogation (Starship Navigation)	85
Astronomy	65
Carousing	45
Computer Operation	64
Leadership	40
Damage Control Procedures	30
Deflector Shield Operation	59
Deflector Shield Technology	38
Electronics Technology	25
Gourmet Cooking	4
Language (Spanish)	40
(Andorian)	10
(English)	40
Starship Weaponry Operation	30
Starship Weaponry Technology	10
Starship Combat Strategy/Tactics	40
Starship Helm Operation	36
Starship Sensors	49

**Distinguishing Physical Characteristics:**

Ortez is darkly handsome, slender, but much stronger than he looks.

**Brief Personal History:**

Cadet Cruise, Military Operations Command.  
 Galaxy Exploration Command, *USS Potemkin*, 2 years.  
 Galaxy Exploration Command, *USS Republic*, 2 years.  
 Ortez is the son of the wealthy trading magnate Carlos Ortez. His closest friend on board is First Officer Thonen. The two served together aboard the *USS Republic*, Thonen as Chief Navigator, Ortez as his most promising young subordinate. Indeed, Ortez owes his current post to Thonen's recommendation; when he first transferred aboard *Hastings*, Ortez was assistant navigator. The Navigator was killed on landing party duty only a short time thereafter, and Thonen recommended Ortez as department head over a request for a more senior replacement from Star Fleet. His work has justified Thonen's confidence in him, and a promotion to full Lieutenant is pending.

**Personality****Motivations/Desires/Goals:**

Ortez is still finding himself, so to speak. He joined Star Fleet in a gesture of defiance towards his father. He has no clear goal in life; having discovered an aptitude for astrology, he is impelled to further his career, but, at the same time, he has little interest in gaining rank or a higher position. He likes a well-done job at the navigation console, the attentions of pretty women, and a good time on shore leave, not necessarily in that order.

**Manner:**

Hot-blooded and excitable, José Ortez makes a startling contrast to his stoic Vulcan companion at the helm/navigation console of the *Hastings*. Strings of Spanish oaths and other emotional outbursts are apt to accompany any difficult maneuver or stress situation that Ortez is involved in, which frequently sparks disdainful observations on the part of Lt. Saalik concerning the waste of energy and general inefficiency of Humans in general and Human navigators in particular. (The relationship between Ortez and Saalik is not unlike the famous Spock-McCoy relationship; both disparage the attitudes and actions of the other, but their barbed comments mask a deep and genuine respect and loyalty to one another.)

The navigator, something of a lady's man, enjoys shore leaves immensely, and is said to be able to locate a bar or cantina from up to 10 parsecs away. His other most interesting pursuit, gourmet cooking, is something of an in-joke aboard the *Hastings*. Though he claims to be talented in this area, most of his attempts have fallen short of the mark in one way or another, and an oft-threatened disciplinary action on board is to transfer Ortez to galley duty to shape up the whole vessel.

**Special Knowledge/Powers:**

None.

**Name: TRAVERS, David Arthur****NPC ONLY**

**Rank:** Lieutenant  
**Current Assignment:** Military Operations Command,  
*USS Hastings, NCC-4405*  
*Position:* Chief Security Officer

**Race:** Human  
**Sex:** Male  
**Age:** 31

STR — 76                      CHA — 72  
 END — 75                     LUC — 57  
 INT — 71                     PSI — 01  
 DEX — 73  
 To-Hit, Modern: 80  
 H-T-H: 84  
 Knife: 41                     AP — 11

Bare-Hand Damage: 2D10+4

**Important Skills**

<i>Skill</i>	<i>Rating</i>
Computer Operation	40
General Medicine (First Aid)	13
Language (English)	40
(Klingonese)	10
Leadership	49
Personal Weapons Technology	40
Security Procedures	54
Shuttlecraft Pilot	37
Small Unit Tactics	60

**Distinguishing Physical Characteristics:**

Travers is very muscular and robust, with rugged features and craggy good looks. His habitual expression is grim.

**Brief Personal History:**

Cadet Cruise, Galaxy Exploration Command, *USS Enterprise*.  
 Colonial Operations Command, 3 years.  
 Galaxy Exploration Command, 2 years.  
 Lt. David Travers is the son of Base Commandant Travers, killed in the Gorn raid on Cestus III. He is a highly competent and dedicated officer. Since his parents' deaths (his mother was Chief Medical Officer at the Cestus III outpost), Travers has thrown himself into his work more than ever, and has become single-minded to the point of near-fanaticism with regard to his security duties.

**Personality****Motivations/Desires/Goals:**

His father's death shapes the primary personality trait exhibited by Travers (at least for this adventure) — a deep and fierce hatred and distrust of the Gorn.

**Manner:**

Travers is rather opinionated and often borders on insubordination or worse. He is designed to be an NPC, and his reactions are programmed throughout the adventure. Some specific actions and reactions to various events in the adventure are pointed out in appropriate places throughout the main text. If there are enough players, and one player is willing to cooperate, the referee may assign Travers to a player, who should be thoroughly briefed on the attitudes of the Security Chief and be willing to respond according to these characteristics and feelings as the need arises. The Travers character should not be replaced or modified in this adventure.

As an NPC, Travers may be considered somewhat expendable. It would be a nice touch and thoroughly in keeping both with the concept of this adventure and the *STAR TREK* tradition if Travers should be rescued from certain death by the actions of one of the pro-Federation Gorn (S'slee, for instance); this is especially effective if Travers were played by a player.

**Special Knowledge/Powers:**

None.

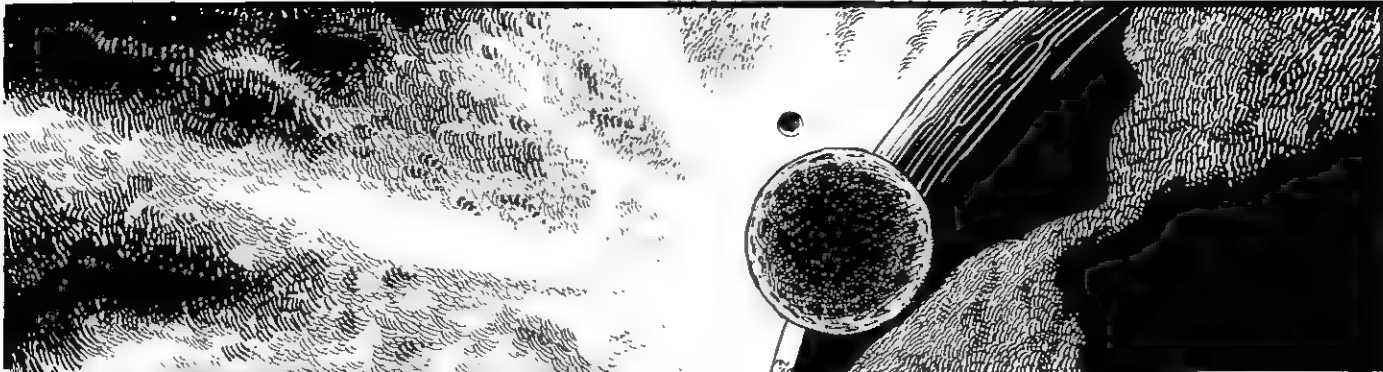

## SECONDARY OFFICERS

**Name: OBOTE, Yussufu**  
 Rank/Title: Lieutenant  
 Current Assignment: Military Operations Command,  
*USS Hastings, NCC-4405*  
 Position: Assistant Engineering Officer  
 Race: Human  
 Sex: Male  
 STR65 END69 INT74 DEX68 CHA62 LUC30 PSI22  
*Important Skills* *Rating*  
 Astronautics (Starship Engineering) 79  
 Mechanical Engineering 67  
 Warp Drive Technology 68

**Name: MITCHELL, Robert S.**  
 Rank/Title: Lieutenant, JG  
 Current Assignment: Military Operations Command,  
*USS Hastings, NCC-4405*  
 Position: Assistant Science Officer  
 Race: Human  
 Sex: Male  
 STR56 END57 INT81 DEX63 CHA67 LUC86 PSI01  
*Important Skills* *Rating*  
 Astronomy 77  
 Starship Sensors 65

**Name: PETROVICH, Alexei**  
 Rank/Title: Lieutenant, JG  
 Current Assignment: Military Operations Command,  
*USS Hastings, NCC-4405*  
 Position: Assistant Helmsman  
 Race: Human  
 Sex: Male  
 STR64 END64 INT65 DEX73 CHA70 LUC66 PSI01  
*Important Skills* *Rating*  
 Starship Weaponry Operation 53  
 Starship Helm Operation 58

**Name: MARKHAM, Peter**  
 Rank/Title: Lieutenant, JG/M.D.  
 Current Assignment: Military Operations Command,  
*USS Hastings, NCC-4405*  
 Position: Assistant Medical Officer  
 Race: Human  
 Sex: Male  
 STR54 END53 INT87 DEX78 CHA65 LUC40 PSI01  
*Important Skills* *Rating*  
 General Medicine (Andorian) 29  
                                   (Human) 66  
                                   (Vulcan) 35

**Name: COLLINGWOOD, Elizabeth**  
 Rank/Title: Lieutenant, JG  
 Current Assignment: Military Operations Command,  
*USS Hastings, NCC-4405*  
 Position: Assistant Security Chief  
 Race: Human  
 Sex: Female  
 STR60 END58 INT72 DEX89 CHA75 LUC55 PSI26  
*Important Skills* *Rating*  
 Marksmanship, Modern 62  
 Personal Combat, Unarmed 75  
 Small Unit Tactics 36  
 Security Procedures 63

**Name: COCHRANE, Anthony**  
 Rank/Title: Ensign  
 Current Assignment: Military Operations Command,  
*USS Hastings, NCC-4405*  
 Position: Assistant Navigator  
 Race: Human  
 Sex: Male  
 STR63 END66 INT79 DEX63 CHA67 LUC10 PSI01  
*Important Skills* *Rating*  
 Astrogation (Starship Navigation) 73  
 Deflector Shield Operation 57  
 Deflector Shield Technology 42  
 Anthony Cochrane is a descendant of Zefram Cochrane, inventor of the Warp Drive; he must make a considerable effort living up to the Cochrane family tradition.

**Name: MUELLER, Karl**  
 Rank/Title: Ensign  
 Current Assignment: Military Operations Command,  
*USS Hastings, NCC-4405*  
 Position: Assistant Communications Officer  
 Race: Human  
 Sex: Male  
 STR70 END71 INT71 DEX70 CHA84 LUC49 PSI55  
*Important Skills* *Rating*  
 Communications Systems Operation 60  
 Damage Control Technology 42  
 First deep-space assignment.

**Name: WOLFE, Andrea**  
 Rank/Title: Petty Officer, 1st Class  
 Current Assignment: Military Operations Command,  
*USS Hastings, NCC-4405*  
 Position: Transporter Chief  
 Race: Human  
 Sex: Female  
 STR60 END55 INT67 DEX60 CHA68 LUC69 PSI01  
*Important Skills* *Rating*  
 Starship Sensors 65  
 Transporter Operation Procedures 79  
 Transporter Systems Technology 81

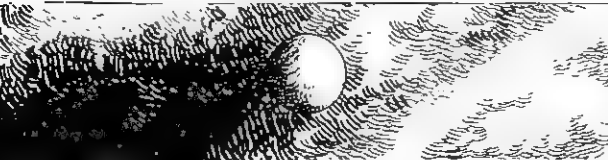



## INCIDENTAL CREW MEMBERS

**Name: IMMANURA, Richard**  
 Rank/Title: Chief Petty Officer  
 Current Assignment: Military Operations Command,  
 USS Hastings, NCC - 4405

Position: Security Guard

Race: Human  
 Sex: Male  
 STR75 END78 INT50 DEX75 CHA 46 LUC 22 PSI01  
*Important Skills* *Rating*  
 Marksmanship, Modern 58  
 Personal Combat, Unarmed 56  
 Security Procedures 45

**Name: LANIER, Geoffrey "Studs"**  
 Rank/Title: Enlisted First Class  
 Current Assignment: Military Operations Command,  
 USS Hastings, NCC - 4405

Position: Security Guard

Race: Human  
 Sex: Male  
 STR71 END74 INT50 DEX75 CHA46 LUC22 PSI01  
*Important Skills* *Rating*  
 Marksmanship, Modern 58  
 Personal Combat, Unarmed 56  
 Starship Security 45

**Name: THANAS, K'Iros**  
 Rank/Title: Enlisted First Class  
 Current Assignment: Military Operations Command,  
 USS Hastings, NCC - 4405

Position: Security Guard

Race: Andorian  
 Sex: Male  
 STR86 END84 INT50 DEX68 CHA44 LUC19 PSI14  
*Important Skills* *Rating*  
 Marksmanship, Modern 57  
 Personal Combat, Unarmed 66  
 Security Procedures 44

**Name: THOMAS, Estabrook**  
 Rank/Title: Enlisted Second Class  
 Current Assignment: Military Operations Command,  
 USS Hastings, NCC - 4405

Position: Security Guard

Race: Human  
 Sex: Female  
 STR78 END78 INT50 DEX74 CHA50 LUC29 PSI39  
*Important Skills* *Rating*  
 Marksmanship, Modern 51  
 Personal Combat, Unarmed 53  
 Security Procedures 44

**Name: TRACEY, Meagan**  
 Rank/Title: Ensign  
 Current Assignment: Military Operations Command,  
 USS Hastings, NCC - 4405

Position: Nurse

Race: Human  
 Sex: Female  
 STR55 END55 INT72 DEX60 CHA69 LUC42 PSI33  
*Important Skills* *Rating*  
 General Medicine (Human) 28  
 Psychology (Human) 29



**Name: WINDER, Athenia**  
 Rank/Title: Enlisted First Class  
 Current Assignment: Military Operations Command,  
 USS Hastings, NCC - 4405

Position: Yeoman

Race: Human  
 Sex: Female  
 STR 50 END 50 INT 75 DEX 68 CHA 68 LUC 54 PSI 22  
*Important Skills* *Rating*  
 Skill  
 Administration 68  
 Marksmanship, Modern 49

## Name: PRICE, Caroline

Rank: Lieutenant

Title:

Current Assignment: Detached Duty, Diplomatic Corps

Position: Liaison Officer, Clanhaven Embassy

Race: Human

Age: 36

Sex: Female

STR — 55

CHA — 87

END — 55

LUC — 67

INT — 82

PSI — 68

DEX — 66

To-Hit, Modern: 43

UNC SAVE LVL — 27

H-T-H: 43

UNC THRESH — 5

Bare-Hand Damage: 1D10+3

AP — 10

## Important Skills

Skill	Rating
Language (Andorian)	33
(English)	40
(Gorn)	25
(Vulcan)	27
Negotiation/Diplomacy	66
Psychology (Gorn)	20
Racial Culture/History (Andorian)	27
(Gorn)	22

## Distinguishing Physical Characteristics:

Caroline Price is short, slight, and rather delicate in appearance, which is emphasized when she is among the Gorn.

## Brief Personal History:

Lt. Price is a Star Fleet officer, but has been on prolonged detached duty with the Diplomatic Corps as a liaison officer. As such, she has served on Admiral Mendez's staff since the beginning of the Gorn conferences, and is the Admiral's specialist in Gorn culture, language, and psychology.

## Personality

## Motivations/Desires/Goals:

The lieutenant's strongest fear is of making a mistake, which makes her cautious and easily flustered. She hopes for a chance to transfer full-time to the Diplomatic Corps, but the chance is highly unlikely, for the moment at least.

## Manner:

Price is, unfortunately, something of a ditherer, afraid to make a move that could upset the Gorn and all too much aware of how little she really knows of their ways.

## Special Knowledge/Powers:

Price is meant to be a source of information, but such information should be volunteered only when the situation obviously warrants it. For the most part, she must be questioned by player characters before the knowledge she holds can become known. The Lieutenant is also a useful way for the Gamemaster to keep player characters from acting too rashly; she will frequently interject cautionary notes, warning the *Hastings* crew against antagonizing the Gorn, even if, in reality, there is no real danger of this. Lt. Price is too concerned in this area, sometimes.

## Name: S'SLEE

Rank: Captain

Title:

Current Assignment: Detached Duty,  
Alliance Peach Embassy

Position: Envoy

Race: Gorn

Sex: Male

Age:

STR — 94

CHA — 39

END — 88

LUC — 41

INT — 62

PSI — 22

DEX — 44

To-Hit, Modern: 44

UNC SAVE LVL — 44

H-T-H: 54

UNC THRESH — 8

Bare-Hand Damage: 2D10+1

AP — 8

## Important Skills

Skill	Rating
Language (Galacta)	48
Leadership	10
Marksmanship, Modern	45
Negotiation/Diplomacy	34
Personal Combat, Unarmed	65
Starship Weaponry Operation	47
Starship Weaponry Technology	35
Starship Combat Strategy/Tactics	53
Starship Helm Operation	27

## Distinguishing Physical Characteristics:

To a non-Gorn, one Gorn is pretty much like another. S'slee is marked with several ragged scars on his body, the result of his duel with Captain Kirk, but these generally are hidden by his clothing.

## Brief Personal History:

S'slee commanded the raid on Cestus III in the first incursion of the Gorn into Federation space. He fought a duel with Captain Kirk of the *Enterprise* (as retold in the section on **Background Information**). He is the son of the actionist Autarch now in command of the renegades.

## Personality

## Motivations/Desires/Goals:

S'slee is dedicated to the Gorn way of life, but has a certain amount of admiration for Humans, largely due to Captain Kirk. Though he will turn against the Federation if he becomes convinced that they wish to harm him or the Alliance, he will not be swayed easily from his true desire to seek peace.

Once he discovers that the renegades have killed his comrade on the courier ship, S'slee's inner motivations are at odds. One demand of Honor compels him to seek a negotiated settlement with his father's band, and another urges him towards vengeance. The Gorn have little in the way of filial or familial ties, replacing these with demands of Honor that draw them one way or another. A Gorn obeys a parent only if that is the honorable thing to do.

## Manner:

S'slee's manner is shaped strongly by Gorn philosophical concepts of obligation, responsibility, and honor. Though he admires Humans, and he is interested in their ways, he is first, last, and always a Gorn.

## Special Knowledge/Powers:

None.

**Name: SLAS'SARN****Rank:***Title:***Current Assignment:** Alliance Peace  
Embassy Staff*Position:* Diplomatic Aide**Race:** Gorn**Sex:** Male**Age:**

STR — 93

CHA — 42

END — 87

LUC — 49

INT — 69

PSI — 19

DEX — 48

To-Hit, Modern: 57

UNC SAVE LVL — 43

H-T-H: 53

UNC THRESH — 8

Bare-Hand Damage: 2D10+1 AP — 8

**Important Skills**

<i>Skill</i>	<i>Rating</i>
Language (English)	16
Leadership	66
Marksmanship, Modern	66
Negotiation/Diplomacy	58
Personal Combat, Unarmed	58
Shuttlecraft Pilot	32
Starship Helm Operation	29

**Distinguishing Physical Characteristics:**

A ragged scar on Slas'sarn's neck and throat marks the wound scored by flying shards of metal, the result of a bridge hit in a starship combat several years ago.

**Brief Personal History:**

Slas'sarn is a secret actionist who has been planted on the peace embassy to delay the proceedings and otherwise hinder the pro-peace movement. He has been feeding false information to the diplomats of both sides, and arguing persuasively behind the scenes each time Federation actions can be twisted as evidence of belligerence or improper intents. He very nearly caused a major rupture over the issue of having the Alliance fleet deal with the renegades. When S'slee was able to halt the walkout, Slas'sarn sabotaged the Gorn embassy ship to delay S'slee's mission.

**Personality***Motivations/Desires/Goals:*

Slas'sarn is doing his best to provoke Federation-Gorn confrontations along the frontier. He (and the other actionist renegades) wants war, and to this end he has evolved an elaborate and flexible plan that, he hopes, will force the Federation and the Alliance into open war. The object is to trick the Federation into actions that will 'prove' the Federation's intent to destroy Gorn culture.

The events leading up to and occurring on Maltharin II, brought about by treachery and deception, are designed to implement Slas'sarn's plan, subtle by Gorn standards and endorsed by the renegade actionist Autarch, S'grisslor (S'slee's father). The actionists have carried out raids against Federation shipping and undefended worlds with the aim of causing Star Fleet to bring in additional military vessels in violation of the Frontier Accord. Slas'sarn hopes to get the Federation blamed for some major debacle; hence the overloaded phaser in S'slee's quarters and all Slas'sarn's arguments. His major plan, is to draw the *Hastings* into an ambush and cause a major rupture between the Alliance and the Federation.

In Gorn eyes, deceptions and lies are not necessarily dishonorable. In the interlocking series of right and wrong, Honor and Dishonor, which make up the Warrior's Code, loyalty is given to various imperative 'Demands of Honor'. Frequently, one demand must give way to another, higher imperative. Just as S'slee was impelled in one direction by his mission of peace, and in another by obligations to his dead friend, so the actionists may act in a fashion contrary to honor on one level if it is in support of another, more urgent imperative.

*Manner:*

Slas'sarn has been cultivating Lt. Price very carefully throughout the peace talks. Much of her 'knowledge' of Gorn culture is inaccurate, fed to her by Slas'sarn to slow negotiations down further by worrying Federation diplomats with the highly delicate nature of negotiation with the Gorns. Though complex and alien, the Gorn are not quite so prone to take offense as Lt. Price believes.

Slas'sarn offers no unsolicited assistance except in conjunction with his own schemes. He is apt to provide false information if he can do so subtly (for a Gorn) or without risk of being caught.

**Special Knowledge/Powers:**

None.

**Name: GRIS'LASS****Rank/Title:****Current Assignment:** Alliance Peace Embassy Staff*Position:* Diplomatic Aide**Race:** Gorn**Sex:** Male

STR 98 END 87 INT 53 DEX 38 CHA 35 LUC 32 PSI 17

**Important Skills**

<i>Skill</i>	<i>Rating</i>
Leadership	54
Negotiation/Diplomacy	40

Gris'lass is a nonentity, provided only to confuse the track somewhat. Highly suspicious players may overlook Slas'sarn, who is obvious in his anti-Federation stance, and seek to fix the blame for actions such as the attempt to kill S'slee on the quiet, unobtrusive suspect. This is Gris'lass's only real purpose in the game.

**Body Guards****Current Assignment:** Alliance Peace Embassy Staff*Position:* Bodyguards**Race:** Gorn**Sex:** Males

STR 90 + 2D10      END 85 + 2D10      INT 30 + 2D10

DEX 25 + 2D10      CHA 10 + 2D10      LUC 20 + 2D10

PSI 10 + 2D10

**Important Skills**

<i>Skill</i>	<i>Rating</i>
Marksmanship, Modern Weapon	40 + 2D10
Small Unit Tactics	40 + 2D10
Unarmed Personal Combat	65 + 2D10

S'slee's retinue contains five Gorn bodyguards. Two are secretly loyal to Slas'sarn, and will join him if he is allowed to leave the *Hastings*.

# HINTS FOR PLAY

## JUDGING THE ADVENTURE

### PC OR NPC, THAT IS THE QUESTION

Either the Captain should be the pregenerated character played by a player as he sees fit, or he should be replaced by a player character; he should not be an NPC. The Security Chief, on the other hand, is an important focal point of the action in this adventure. Thus, either he should be the pregenerated character played by a player who has agreed to play him as described, or he should be an NPC; he should not be replaced by a different character. If a player character in an ongoing campaign has the post of Security Chief, then Lt. Travers can become a newly assigned Deputy Chief. Any pregenerated characters not replaced by player characters and not run by a player, will be NPCs under the control of the gamemaster.

### DIVIDING THE PLAY

*Demand Of Honor* is structured like a 2-part *STAR TREK* episode or a movie; it falls into two fairly neat divisions. The first part gives the background for the adventure and builds the tension aboard ship while transporting the Gorn. It builds to a climax when the Gorn courier is discovered and the destroyer is ambushed by the Gorn cruiser from the asteroid belt. The second section deals with events on Maltharin II, ending with the all-out space battle and the resolution of the adventure. When running the adventure, it is probably advisable to break it into two gaming sessions corresponding to these sections.

### ROLEPLAYING GORN CHARACTERS

The Gorn make interesting opponents. They are not sneaky and devious in the way Klingons are, nor are they as grimly efficient as the Romulans. They are brave, warlike, and extremely aggressive, tempered with a sense of honor and duty, but as alien in their thoughts and actions as they are in looks. This makes them especially useful as opponents, because they can be used in unexpected ways. Romulans cannot cross the Neutral Zone, and Klingons are bound by the Organian treaty, but the Gorn are much more free to act and interact freely with the Federation, and their factional approach to government makes it possible for them to appear as friends, foes, or both.

The Gorn are as subtle as a battering ram. Their actions are bold and blunt, lacking almost totally in grace; force instead of finesse is the watchword. Gorn equipment mirrors this, with large buttons designed to be slapped instead of pushed, and with heavy-duty levers instead of toggle switches. Thus, Slas'sarn's 'subtle' and 'devious' behavior should be totally transparent, perhaps so much so that it is too obvious to players who are used to more hidden motives and behavior. The same should be true of the Gorn ambushes. The jaws of the trap should be early to close when the ambush is sprung, perhaps too early to be very effective. The hidden Gorn cruiser should barely wait until the *Hastings* is within range; to remain hidden much longer is not Gornlike as it is too subtle. Similarly, the ambush of the landing party should occur just as the party materializes in the outpost, even if it means that some of the party have a chance to evade the ambushers.

### SPLITTING PARTIES WITHOUT SPLITTING HEADACHES

When the landing party is taken prisoner, the gamemaster will have to be careful in juggling events back and forth between the starship and the landing party. If a player is controlling characters in both places, make sure that he

realizes that the character in one group will know about the situation facing the other group. Most players are pretty good about such game schizophrenia, but some might try to take unfair advantage of what they might know. Do not let such people get away with spoiling the adventure in this fashion.

One way to get around this, useful if there are many gamers to draw on, is to set up the boarding party and the bridge crew separately in the first half of the adventure, and the landing party, the bridge crew, and the rescue party separately in the second half of the adventure. Ideally, there should be enough players to handle both groups of characters, and a separate gamemaster for each party. The gamemasters can communicate back and forth, and the characters can do so when a communicator is available. The separate parties can be run separately and simultaneously, and preferably in 'real time,' so that the actions of one group can help or hinder the outcomes of the other. If enough people are available, this can be a very enjoyable alternative to the more traditional approach to the adventure.

### SLAS'SARN'S PLAN

Slas'sarn has evolved an elaborate and flexible plan which, he hopes, will force the Federation and the Alliance into open war. The events on Maltharin II are designed to implement that plan.

In the wake of the capture of the landing party, Slas'sarn deliberately allowed the *Hastings* to intercept the subspace radio message from him to the two renegade cruisers. By falsely claiming to be speaking on behalf of S'slee, the Gorn traitor hopes to convince the officers of the *Hastings* that the Alliance has been playing false the whole time. Ideally, the destroyer would flee, abandoning the landing party.

If this were to happen, the actionists could present subtly distorted records of the proceedings to S'slee and to the government, making it look as if the Federation callously abandoned the envoy without provocation. The initial ambush could be explained as a misunderstanding, and S'slee's subsequent confinement as a precaution pending the arrival of someone with sufficient rank to deal with the envoy.

If, on the other hand, the destroyer were not to flee, the renegades would be prepared to go to more elaborate lengths. It is estimated that the *Hastings* would not be able to penetrate the shields, and would therefore be trapped by the arrival of the two cruisers. The ship would be destroyed and elaborate evidence could be faked showing that the Federation ship treacherously opened fire on the outpost during the negotiations, killing many, including S'slee and other government envoys. Slas'sarn, of course, would survive to give testimony to the 'truth' of these events.

To Slas'sarn's thinking, either approach would probably be sufficient to outrage the Alliance, and bring about war. The renegades, of course, want this, for they have preached all along in favor of Gorn 'Destiny' and the need to keep the Federation from imposing limits on Gorn expansion. It should be remembered that, in Gorn eyes, these deceptions and lies are not necessarily dishonorable. In the interlocking series of right and wrong, Honor and dishonor, which make up the Warrior's Code, loyalty is given to various imperative 'Demands of Honor'. Frequently, one demand must give way to another, higher imperative. Just as S'slee was impelled in one direction by his mission of peace, and in another by obligations to his dead friend, so the actionist may act in a fashion contrary to honor on one level if it is in support of another, more urgent imperative.



Incidentally, this same concept makes it possible to distinguish prisoners of war from other individuals. Invoking 'Honor' or requesting to resolve differences through single combat would be an overly simplistic way out of difficulties for the Federation captives. Such an approach would be blocked by the notion that prisoners have no status or honor "unless their captors choose to allow it," as Lt. Price will inform them. This leaves the gamemaster a loophole, in case such a plan is the only plausible way out!

## OUTCOMES OF THE ADVENTURE

Outcomes of this adventure depend very much on the decisions made by the characters during play. Some very broad outlines can be described for the major possibilities.

If S'slee's landing party is left behind and the *Hastings* cuts and runs, the ship will escape unscathed. The gamemaster may feel that a brush with one or both Gorn cruisers will release pentup tensions.

Assuming that the captives either do not get out or attempt escape but are defeated, Slas'sarn's propaganda will be certain to start a war. The players probably won't ever know just how the war breaks out, but war with the Gorn will come, and the gamemaster can use this as the backdrop for further adventures in which the *Hastings* may play a part. A later adventure might reveal Slas'sarn's duplicity and possibly bring new attempts to negotiate a settlement. A fresh encounter might occur with the mysterious Metrons, though both fleets are likely to give them a wide berth.

Should S'slee or his loyal aide escape with the captives, attempts to steal the Gorn courier could succeed, and war will be much less likely. The Gorn will see that the Federation is not attempting deliberate treachery, and the renegades would probably eventually be eliminated or forced to disperse. However, delays caused by recriminations and renewed negotiations will buy valuable time for the renegades. Further adventures might still be set against this backdrop.

If the destroyer does not flee, everything rests on the success they have in rescuing the ground party. Failure will still permit Slas'sarn to try his propaganda ploy, but success is less likely (perhaps about 60%). Should the Gorn envoys be rescued, the chance of a war dwindles away almost to nothing, particularly if the Gorn cruisers can be badly damaged or destroyed in the final battle. This, obviously, is the optimum solution.

The gamemaster should attempt to keep Slas'sarn alive and uncaptured he would make an excellent recurring troublemaker. The death of S'slee's father in the space battle would probably leave Slas'sarn as the major leader and spokesman of the actionist movement, and even if both cruisers are destroyed, Slas'sarn could escape the outpost to make trouble again somewhere else!

This adventure should yield some improvements in character skills. If the destroyer can beat the Gorn cruisers, and especially if this occurs without significant damage to the *Hastings*, the Captain's Skill Rating in *Starship Combat Strategy/Tactics* should certainly be increased somewhat. That Gorn Autarch is a good strategist, and if he's beaten, the Captain deserves to raise the skill in token of his success. Other rewards should be considered for any bridge officer who is particularly successful in either battle or in the attack on the outpost, as the gamemaster deems appropriate. The landing party or parties may also add to skills in the course of their activities.

Finally, characters who came into frequent contact with the Gorn should be given increased or initial Skill Ratings (1D10 for each character is adequate unless the gamemaster deems a higher value more appropriate) in *Language* (Gorn), *Psychology* (Gorn), and *Racial Culture/History* (Gorn). These

skills would make the *Hastings* crew particularly useful to Star Fleet, whether peace or war ensues, and could be useful in working out further adventures later on.

If further campaigns with *Hastings* are considered, it would be wise to transfer Lt. Travers and replace him with an ordinary player character as Security Chief. Travers was worked into the scenario with the particular aim of exploring his interactions with S'slee.

## ALTERING THE ADVENTURE TO A CAMPAIGN IN PROGRESS

### SUBSTITUTING CHARACTERS

For players who wish to use a favorite character, merely replace one of the officers provided aboard the *Hastings* with the player's character. The ranks must be equivalent, and the player character should have skills that will permit the character to perform the job of the pregenerated character being replaced.

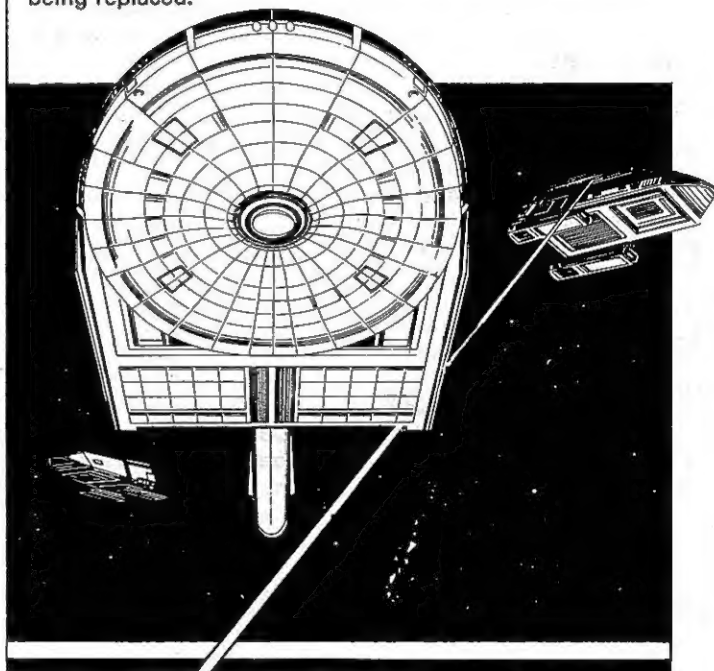

### USING A DIFFERENT STARSHIP

Just as there is some flexibility regarding the characters to be used in this adventure, there are two possibilities for using a different vessel in the adventure while still keeping the final starship combat balanced. The number of Gorn cruisers could be increased to balance a more powerful Federation vessel, or the power of the Gorn vessels could be increased for better balance. If the number of vessels are increased to match a powerful starship like the *Enterprise*, there should be two Gorn cruisers for every 100,000 tons of the player characters' ship. Situations involving a number of Gorn cruisers will be more unwieldy than the version described here, but the adventure can be (and should be) altered to best suit a campaign in progress. The alternative would be to design a larger Gorn ship, say a battlecruiser, that might more closely approximate a larger Federation ship; two of these could be a balanced foe for the *Enterprise* or other large starships. Design of starships is covered in some detail in the *Ship Construction Manual*, available from FASA.

If a larger ship is to be used, then some alteration in the background material will be necessary to modify the restriction imposed by the Accord on the size of military vessel that may be used in the disputed zone. Either modify the size or eliminate the restriction altogether.



Although the Federation and the Gorn Alliance have concluded a treaty, a band of renegade Gorn ships have been raiding Federation shipping. This threatens to jeopardize the peace. The Gorn have told Star Fleet the location of the planet where the renegades have their base. Your destroyer, the *USS Hastings*, has been dispatched to carry a Gorn Ambassador to meet with the renegades.

It seems like a normal mission, but the Ambassador turns out to be none other than the Gorn Captain who fought with Capt. James T. Kirk of the *Enterprise*. He brings aboard with him a squad of 'bodyguards.' Your Security chief senses that something isn't quite right . . .

